



HOT WATER VAPORIZERS
with electric preheat
VAPORIZZATORI AD ACQUA CALDA
con preriscaldamento elettrico
Matr. VE1458

Original document
Documento originale

made for

Gasconcept Kurpinsky S.C.
ref. your order N°12 dtd. 08/07/2022



PEGORARO GAS TECHNOLOGIES S.R.L.
Via Meucci , 77, 36057 Arcugnano (VI), Italia

DICHIARAZIONE DI CONFORMITA' UE
in accordo all'allegato IV della direttiva 2014/68/UE
EU DECLARATION OF CONFORMITY
in accordance to annex IV of directive 2014/68/EU

N. 061/22

Io sottoscritto, nella figura di rappresentante autorizzato, dichiaro sotto la mia esclusiva responsabilità che la progettazione, la fabbricazione, i controlli e le prove delle attrezzature a pressione sotto specificate sono conformi alle disposizioni applicabili della direttiva 2014/68/UE
I undersigned, in the figure of authorized representative, declare under my responsibility that the design, manufacture, inspections and testing of pressure equipment specified below comply with the applicable provisions of Directive 2014/68 / EU

Descrizione insieme <i>Assembly description</i>	VAPORIZZATORE GPL "ECOVAP 150E" LPG VAPORIZERS "ECOVAP 150E"		
Famiglia/ tipo <i>Family/ type</i>	EV2	N. fabbrica <i>Serial no.</i>	VE 1458
Pressione max ammissibile PS <i>Max allowable pressure PS</i>	20 bar		ATM
	GAS SIDE		WATER SIDE
Temperatura min/ max TS [°C] <i>min/ max temperature TS [°C]</i>	-40/120°C		-10/105°C
Capacità fluido (GPL) <i>Fluid volume (GPL)</i>	4,1 L	Capacità fluido (Acqua) <i>Fluid volume (Water)</i>	98 L
Fluido gruppo <i>Fluid group</i>	1		2
Categoria PED	II		Art. 4.3
Procedure di valutazione della conformità utilizzate <i>Conformity assessment procedures used</i>	Modulo H		
Ente notificato <i>Notified body</i>	TUV Italia S.r.l. - n. 0948 Via Carducci,125 - ed.23 - 20099 Sesto San Giovanni (MI)		
Modulo <i>Module</i>	H	Certificato n. <i>Certificate n.</i>	PED-0948-QSH-522-18 Rev.2
Norme tecniche utilizzate <i>Technical standards used</i>	EN 13445 Ed. 2014		

Altre direttive applicate
Other directives applied

Attrezzature componenti l'insieme marchiati CE <i>Other devices data with CE mark</i>	Costruttore <i>Producer</i>	Ente di notifica <i>Notified body</i>	Numero di serie <i>Serial number</i>	Modulo <i>Module</i>
Ecovap 150E 24KW 380V 3ph	Pegoraro G.T.	CE 0948	VE1458	H
LPG Control valve MINI-D 1" feed-out	Pegoraro G.T.	CE 0948	VC00344	Art 4.3
Pressure gauge D63 AISI304 0-25 Bar 1/4" G	Wika	CE0036	-	H
Needle valve 1/4"MF GRC PN50	Guglielmi D.	-	-	Art 4.3
Thermometer 1/2" Ø63 0/120°C	Frat.lli Magni	CE0948	-	Art 4.3
Safety valve F30 18 bar 1/2"M gas	Nova Comet	CE0497	06-22	B+D
Ball valve FB 3/4" MF PN10 H2O	Effebi	CE1370	0322	Art 4.3
Automatic air vent valve 1/2" M RP mod.5020	Caleffi	---	-	Art 4.3
Electrical resistance 2"1/2 24KW 380V	Masterwatt	CE0477	23536	-
Control Box	Pegoraro G.T.	CE 0948	829	-

Luogo e data
Location and date

Vicenza, 22/08/2022





PEGORARO GAS TECHNOLOGIES S.R.L. Via Meucci, 77, 36057 Arcugnano (VI), Italia		VERBALE DI PROVA IDRAULICA HYDRAULIC TEST REPORT		Nr 1458-22/A del 11/04/2022 pag 1 di 1	
CLIENTE/ Customer		GASCONCEPT KURPINSKY S.C.			
ORDINE NR./ Job Nr.		N°12 of 08/07/2022			
Descrizione insieme Assembly description		VAPORIZZATORE GPL ECOVAP 150E LPG VAPORIZERS ECOVAP 150E			
Famiglia/ tipo Family/ type		EV2/150		N. fabbrica Serial no. VE1458	
		LATO GAS/ GAS SIDE		LATO ACQUA/ WATER SIDE	
Pressione max ammissibile (PS) Max allowable pressure (PS)		20 bar		1 bar	
Temperatura min/ max (TS) min/ max temperature (TS)		-40/ +120 °C		-10/ +105 °C	
PRESSIONE DI PROVA IDRAULICA (PT) Hydraulic pressure Test (PT)		28,6 bar		/	
MANOMETRO (SCALA) Manometer range		0/50 BAR	MATRICOLA: Serial N. 504953 (n°16)	0/10 BAR	MATRICOLA: Serial N. 115722 (Nr.15)
FLUIDO DI PROVA TEST FLUID		ACQUA/WATER			
VOLUME (LITRI) Volume (Liter)		4,1		98	
TEMPERATURA DI PROVA (°C) Test Temperature (°C)		AMBIENTE (10°C) Room Temperature (10°C)			
TEMPO DI PERMANENZA IN PRESSIONE Test duration at Test Pressure		MIN./MAX: 4 ORE Min./Max: 4 Hours			
RISULTATO DELL'ESAME Test Result		POSITIVO Positive	X	NEGATIVO Negative	
NOTE/ NOTE					
		EMESSO/ Issued		OPERATORE/ Operator	
FIRMA /Sign		11/04/2022			
ISPETTORE/ Inspector					



PEGORARO GAS TECHNOLOGIES S.R.L.
Via Meucci, 77, 36057 Arcugnano (VI), Italia

DICHIARAZIONE DI CONFORMITA' UE
in accordo all'allegato IV della direttiva 2014/68/UE (SEP)

EU DECLARATION OF CONFORMITY
in accordance to annex IV of directive 2014/68/EU (SEP)

N. 061/22

Io sottoscritto, nella figura di rappresentante autorizzato, dichiaro sotto la mia esclusiva responsabilità che la progettazione, la fabbricazione, i controlli e le prove delle attrezzature a pressione sotto specificate sono conformi alle disposizioni applicabili della direttiva 2014/68/UE
I undersigned, in the figure of authorized representative, declare under my responsibility that the design, manufacture, inspections and testing of pressure equipment specified below comply with the applicable provisions of Directive 2014/68 / EU

Descrizione apparecchiatura <i>Device description</i>	VALVOLA DI CONTROLLO TERMOSTATICO PER GPL "MINI-MINI/D-MINI/DM" LPG THERMOSTATIC CONTROL VALVE "MINI-MINI/D-MINI/DM"		
Modello/ tipo <i>Model/ type</i>	MINI-D	N. fabbrica/Lotto <i>Serial no./Lot.</i>	VC00344
Pressione max ammissibile (PS) <i>Max allowable pressure (PS)</i>	20 bar	Dimensione DN <i>Size DN</i>	1"
Temperatura min/ max TS <i>min/ max temperature TS</i>	-40/+120 °C	Fluido <i>Fluid</i>	GPL LPG
Categoria PED <i>PED category</i>	Art. 4.3 (SEP) Art. 4.3 (SEP)		
Procedure di valutazione della conformità <i>Conformity assessment procedures used</i>	l'attrezzatura a pressione è stata progettata, fabbricata, provata e controllata secondo una corretta prassi costruttiva, come prescritto dalla Direttiva sulle Attrezzature a Pressione 2014/68/UE all' articolo 4 comma 3. <i>the pressure equipment has been designed, manufactured, tested and inspected in accordance with sound engineering practice as prescribed by Pressure Equipment Directive 2014/68/UE, article 4 point 3</i>		
Norme tecniche utilizzate <i>Technical standards used</i>	VSR-M-S ISPEL Ed.99 integrate da EN 13445-5		
Altre direttive applicate <i>Other directives applied</i>	D.M. 16 aprile 2008 (Italia) D.M. 16 of april 2008 (Italy)		

TEST E TARATURE/TEST AND SETTINGS

	Sensore Acqua <i>Water sensor</i>	Sensore Pressione <i>Pressure Sensor</i>	Sensore gas <i>Gas Sensor</i>	Note <i>Notes</i>
Taratura/settings	50°C	//	25°C	
Prova di tenuta/Leak test	(1.1 x PS)	22 bar	Fluido/fluid:	aria/air

MATERIALI/ MATERIALS

Corpo/Body	Ottone/brass UNI EN 12164 CW614N
Stelo pistone/ Piston shaft	AISI 303 EN 10088-3: 2005
Pistone/Piston	AISI 303 EN 10088-3: 2005
Otturatore/Shutter	Ottone+Gomma 70 Sh UNI EN 12164 CW614N Brass+rubber 70 Sh UNI EN 12164 CW614N
Tenute/Seals	NBR 70 Sh PB 701



F.lli CROSTA srl

SISTEMA DI GESTIONE
CERTIFICATO
ITALCERT
UNI EN ISO 9001

TEST CERTIFICATE

CERTIFICATE NUMBER

PGT220344

CODE

36080094

DESCRIPTION

VALV. CONT GPL MINI D 1" 100-200 BIL.

PRODUCTION LOT

1034/22

SERIAL NUMBER

VC00344

PRESSURE TEST

30 [bar]

LEACKAGES

NESSUNA

CHECK 100% N° PIECES

1

PRESSURE TEST MACHINE - SERIAL
NUMBER

VS191202

MACHINE CALIBRATION CERTIFICATE
NUMBER

1A0181UE6IO

DATE 07/07/2022

SIGNATURE

Il Responsabile per la Direzione Qualità

R. F.lli CROSTA S.r.l.
PACCO QUALITÀ

VAPORIZZATORE GPL - LPG VAPORIZER

HEATER ACC. DIR. 2014/34/UE ATEX Ex II 3 G T5

PORTATA FLOW RATE: 150 kg/h TIPO TYPE: 2EV

N.F. SERIAL N. ANNO YEAR

PED CAT. II PESO WEIGHT: 125 Kg

POTENZA POWER: 24 kW TENSIONE VOLTAGE: 380 V

TARATURA VAL. SIC. SAFETY VAL. SET PRES: 17.2 bar

LATO GAS GAS SIDE: PS 20 bar LATO ACQUA WATER SIDE: PS ATM bar

PRESSIONE DI PROVA TEST PRESSURE: PT 28,6 bar

TEMPERATURA MINI MAX TEMPERATURE MIN/MAX: TS -40/+120 °C TS -10/+105 °C

VOLUME CAPACITY: V 4,1 l V 98 l

FLUIDO FLUID: 1 2

ELECTRIC PANEL IP 65

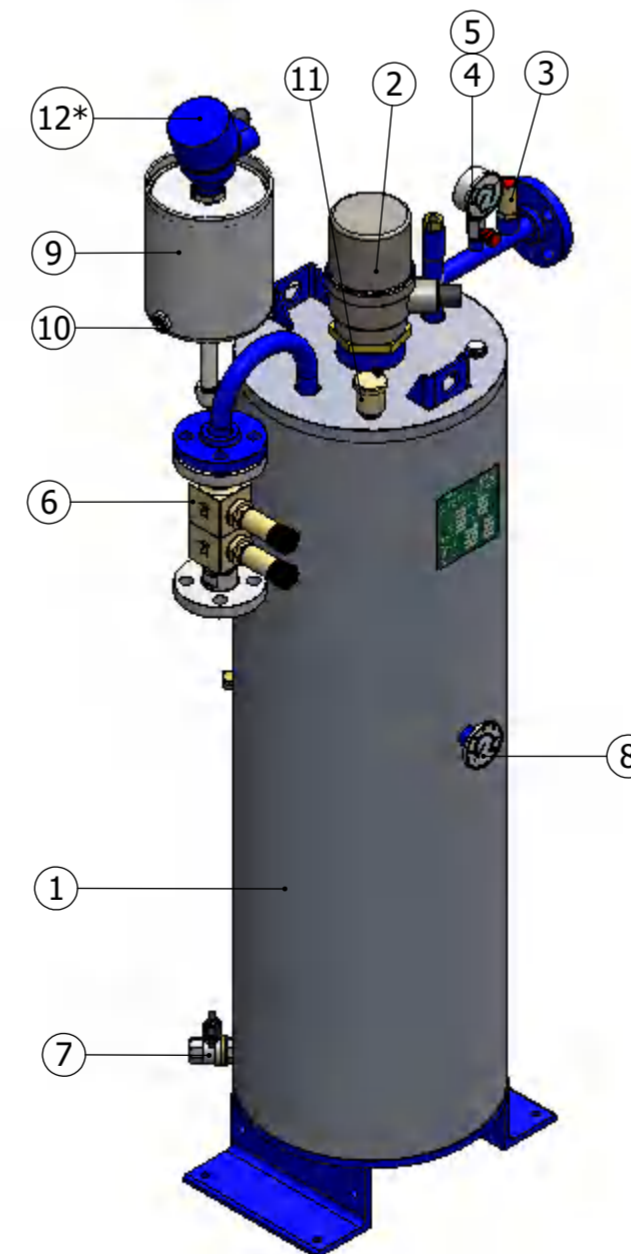
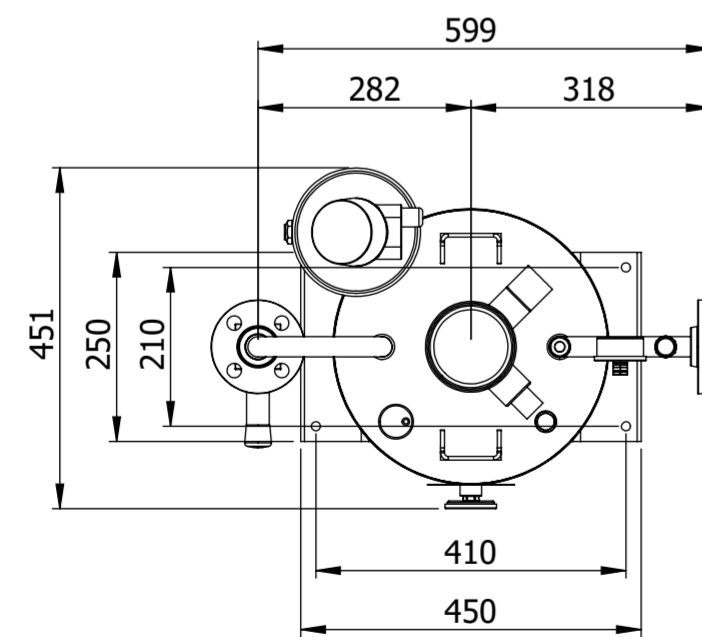
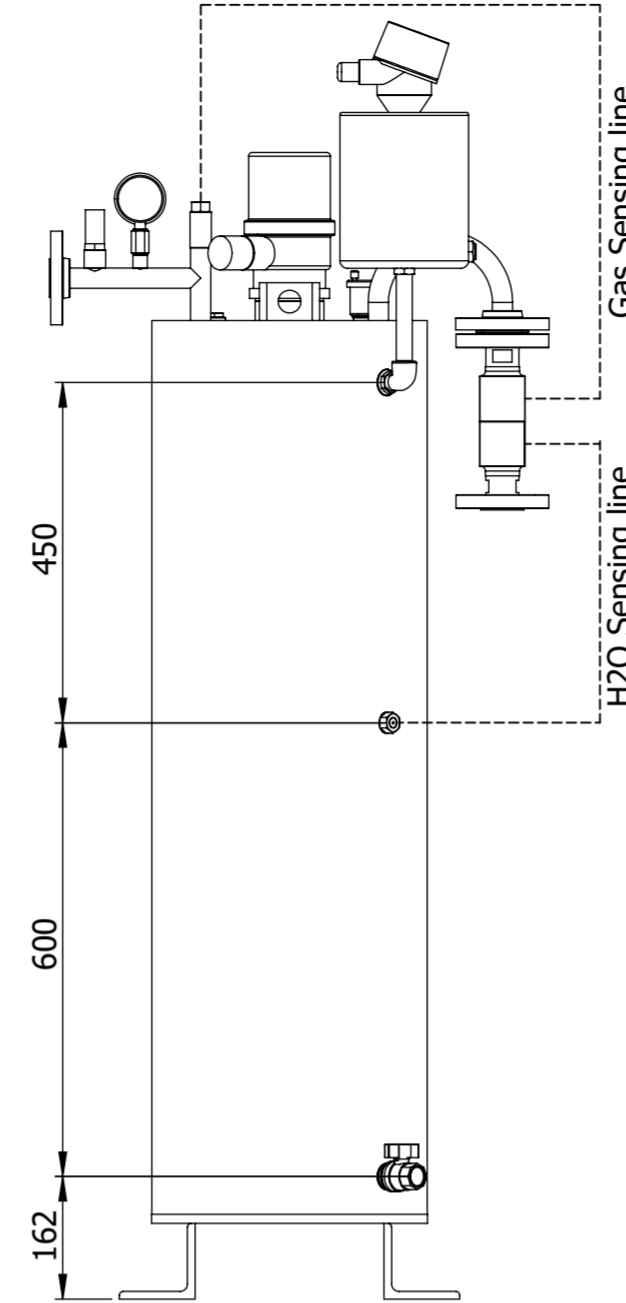
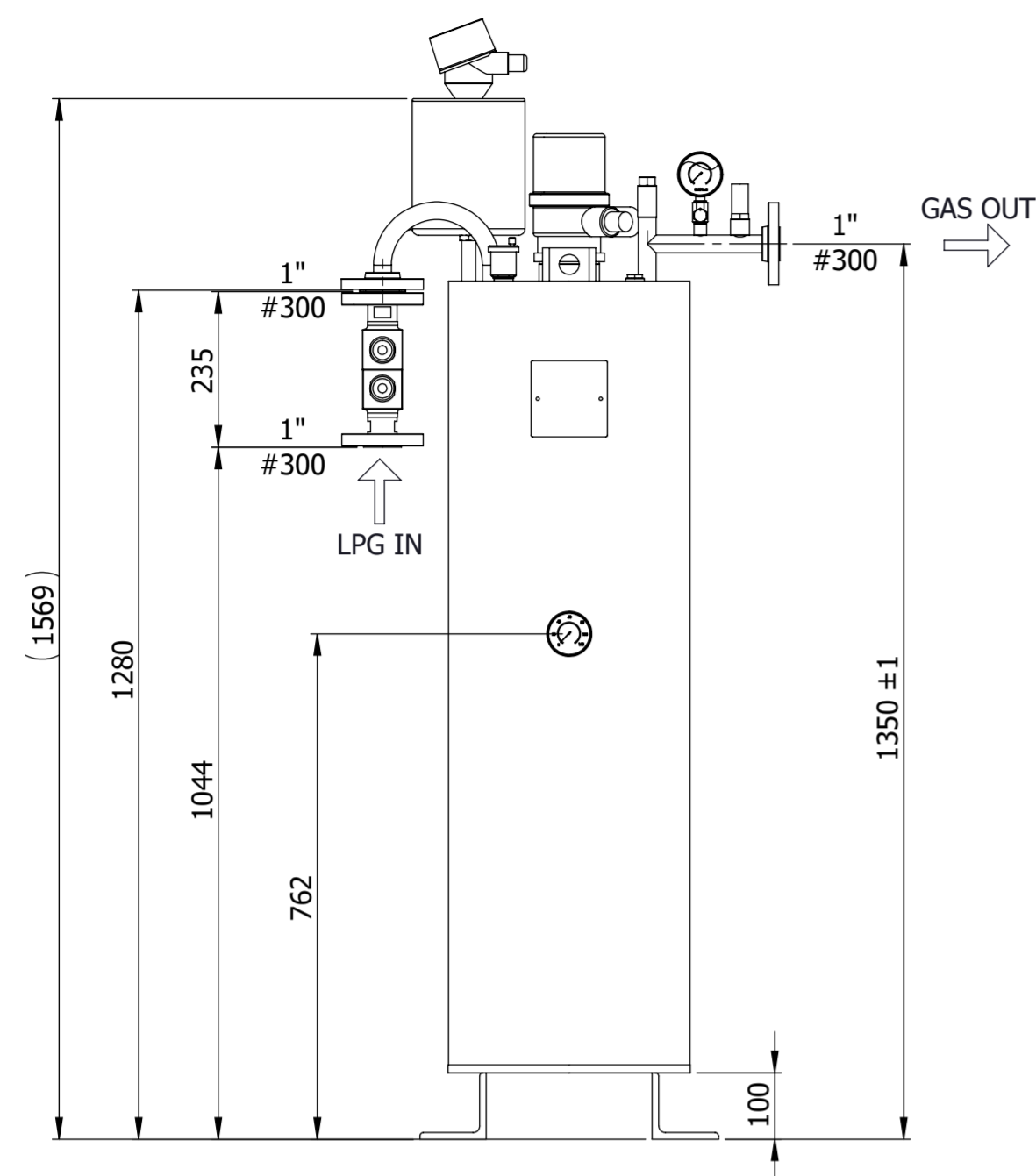
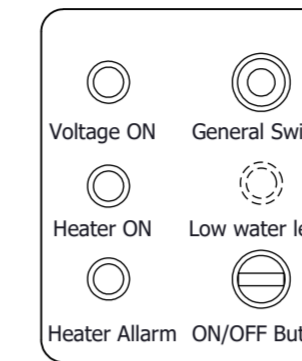
 **LIVELLOSTATO (12) OPZIONALE
LEVEL SWITCH (12) OPTIONAL

DATI DI PROGETTO/DESIGN DATA

Portata/Flow rate	150	Kg/h
Pressone di progetto/Design pressure	20	bar
Pressione massima in ingresso/ Max inlet Pressure	17.2	bar
TS lato gas/TS gas side	-40/+120	°C
TS lato acqua/TS water side	-10+105	°C
Peso/Weight	125	Kg

CALIBRATION

Sensore temperatura H2O/H2O sensing line	50	°C
Sensore temperatura Gas/Gas sensing line	26	°C
Valvola di blocco di minima/Min. Slut shut valves		Bar
Valvola di sicurezza/Safety valve	17.2	Bar

PED Certificated: II

12	1	36090024	Livellostato inox EEXD 1" L=180 - Level switch SS EEXD 1" L=180		
11	1	36090006	Scaricatore automatico aria 1/2" Rp - Air vent 1/2" Rp		1/2"Rp
10	1	36090002	Spia indicatore livello visivo 1/2"Rp - Indicator level 1/2"Rp		1/2"
9	1	36090012	Vaso espansione 4.5 Litri - Expansion Vessel 4.5 Liter		
8	1	11010010	Termometro d.63 0/120°C 1/2" h2o - Thermometer d.63 0/120°C 1/2" h2o		1/2"Rp
7	1	25100033	Rubinetto a sfera ottone 3/4"MF PN10 - Brass ball valve 3/4"MF PN10		3/4"Rp 10
6	1	36080071	Valvola di controllo GPL mini-D1" - LPG control valve mini-D1"		
5	1	9010008	Manometro Ø60 0-25bar G1/4"RP - Pressure gauge Ø60 0-25bar G1/4"RP		1/4"Rp
4	1	10020002	Valvola a spillo 1/4"RC M/F PN50 - Needle Valve M/F 1/4"RC PN50		1/4"Rc PN 50
3	1	16040000	Valvola di sicurezza 18 bar 1/2"M - Safety valve 18 bar 1/2" M		1/2"Rc
2	1	39010022	Electrical resistance 24 kW 380V - 2 1/2"		
1	1	6040021	Scambiatore GPL ECOVAP 100EA-150EA-200A - LPG Heat Exchanger for ECOVAP 100EA-150EA-200A		

Posiz.	Q.tà	Codice	Descrizione	DN	PN/ANSI
C					
B					
A					

IND.	MODIFICA / MODIFICATION	DATA / DATE	SIGLA / NAME

TOLLERANZE / TOLERANCES	SCALA SCALE: 1:10	MATERIALE MATERIAL	RESISTENZA STRENGTH Kg/mm ²	DISEGNATO DRAWN	DATA DATE
LUNGH. ANGOLI SMUSSI RAGGI LENGTH ANGLES BEVELS RADIUS			DUREZZA HARDNESS HRC	M.C.	15/03/2022
UNI-ISO 2768 m	TRATTAMENTO TREATMENT		PROFONDITA' DEPTH mm	CONTROLLATO CONTROLLED	DATA DATE
FORI HOLES H13 ALBERI SHAFTS H13			PESO WEIGHT 128 Kg	S.C.	15/03/2022

VAPORIZZATORE GPL 24KW 380V ECOVAP 150E - LPG VAPORIZER 24KW 380V

UNI A2	FOGLIO / SHEET 1/1	SOSTITUISCE IL REMPLACE THE SOSTITUITO DAL REPLACED FROM	CODICE CODE 36040102	00
--------	--------------------	--	----------------------	----



“ECOVAP” HOT WATER VAPORIZER

“ECOVAP” HOT WATER VAPORIZER WITH ELECTRIC PREHEATING



USE AND MAINTENANCE INSTRUCTIONS

Edition 09.2019 Rev.3

REVISION	DESCRIPTION	ISSUE BY	APPROVED BY	DATE
3	General revision	S.C.	L.P.	04/09/2019
2	Editing and integration	S.C.	L.P.	20/12/2018

	TECHNICAL DOCUMENTATION In conformity with Directive 2014/68/CE	Family EV2
		Doc. MU EV2 - Rev.03
	USE AND MAINTENANCE INSTRUCTIONS	Pagina 2 di 38

INDEX

1. INTRODUCTION	4
1.1 FOREWORD AND IMPORTANT WARNINGS	4
1.2 MANUAL UPDATING	5
1.3 COPYRIGHT	5
1.4 DESCRIPTION OF PICTOGRAMS AND SYMBOLS	6
1.5 APPLIANCE INTENDED PURPOSE	7
2. TECHNICAL CHARACTERISTICS.....	8
3. HANDLING	12
4. INSTALLATION.....	13
4.1 VERSION WITH ELECTRIC PREHEATING	14
4.1.1 ELECTRICAL CONNECTION	14
4.1.2 ELECTRICAL CONNECTION	16
4.1.3 WATER LEVEL SWITCH (OPTIONAL).....	16
4.1.4 FILLING THE WATER CIRCUIT	16
4.2 HOT WATER VERSION.....	19
4.2.1 CONNECTIONS	19
4.2.2 BOILER REQUIREMENTS.....	19
4.2.3 FILLING THE WATER CIRCUIT	19
5. COMMISSIONING.....	19
5.1 VERSION WITH ELECTRIC PREHEATING	20
5.1.1 CHECKS AND CONTROLS	21
5.2 HOT WATER VERSION.....	22
5.2.1 CHECKS AND CONTROLS	23
5.3 GENERAL WARNINGS FOR THE CORRECT OPERATION OF THE VAPORIZER.....	23
6. TROUBLESHOOTING.....	24
7. HOW THE CONTROL VALVE WORKS (called the “VALVE”) AND HOW TO SET IT.....	25
7.1 HOW THE VALVE WORKS.....	25
7.2 VALVE SETTING	25
8. MAINTENANCE	28
8.1 FILTER FITTED ON THE VALVE WATER SIDE.....	28
8.2 EXCHANGER.....	28
8.3 CONTROL VALVE	29
8.3.1 ROUTINE MAINTENANCE	29
8.3.2 SPECIAL MAINTENANCE	30

	TECHNICAL DOCUMENTATION In conformity with Directive 2014/68/CE	Family EV2
	USE AND MAINTENANCE INSTRUCTIONS	Doc. MU EV2 - Rev.03 Pagina 3 di 38

8.4 CONTROL VALVE WITH OPENING AND CLOSING VIEWER.....	33
8.4.1 SPECIAL MAINTENANCE	33
8.5 SUMMARY OF THE MAINTENANCE TO BE CARRIED OUT.....	36
9. DEMOLITION.....	36
10. ENCLOSED DOCUMENTATION	36

	TECHNICAL DOCUMENTATION In conformity with Directive 2014/68/CE	Family EV2
	USE AND MAINTENANCE INSTRUCTIONS	Doc. MU EV2 - Rev.03 Pagina 4 di 38

1. INTRODUCTION

1.1 FOREWORD AND IMPORTANT WARNINGS

The **USE AND MAINTENANCE MANUAL** describes the plant operation and the correct procedures for carrying out the main use and routine maintenance.

The indications given in this manual are destined to a professional user who must have specific knowledge on the plant procedures of use, who must be suitably authorised, instructed and trained for the correct use and commissioning of the system so as to guarantee uninterrupted plant operation.

It is advised to read it careful before commissioning the plant. The manual must be kept in its specific housing on the plant or in an easily accessible place, protected against damage and always available for whatsoever future consulting requirements.

This manual must be complete and readable in all its parts, all operators who use the plant, or the person responsible for maintenance or regulation operations, must know where it is kept and must be able to consult it at any moment.

Should it be damaged or lost, you must ask for a new copy from the plant manufacturer. Should the plant be transferred to another owner, the manual must be handed over to the new user. The manual is considered an integral part of the plant.

For all components and appliances produced by third parties, please refer to the instructions included in their respective manuals.

The manual has been conceived so as to provide the user with all necessary information for using the plant in safe conditions, from the transport phase to scrapping.

The instructions given by this Use & Maintenance Manual are complementary to the accident regulations in force in the country of use of the plant (the instructions are not exhaustive but complementary to the safety provisions and/or requirements issued by the individual countries)

	TECHNICAL DOCUMENTATION In conformity with Directive 2014/68/CE	Family EV2
	USE AND MAINTENANCE INSTRUCTIONS	Doc. MU EV2 - Rev.03 Pagina 5 di 38

1.2 MANUAL UPDATING

The information, descriptions and illustrations contained in this manual respect the state of the art at the moment the plant is placed on the market for the first time.

The Manufacturer reserves the right to make any changes to the type of plant at any time for technical or commercial reasons. Said changes do not require the Manufacturer to intervene on the plants that have already been placed on the market until that moment nor to consider this manual inadequate.

Any additions that the Manufacturer may deem appropriate to provide on a later date must be kept together with the manual and considered an integral part of it.

Although this manual contains the most up-to-date information, there may be minor differences between your plant and the one described in this booklet.

If you find any printing errors or indications that are unclear to you, or if you have any other concerns, contact your supplier.

1.3 COPYRIGHT

The copyright of this manual belongs to the plant Manufacturer.

This manual contains texts, drawings and illustrations of a technical nature that may not be disclosed or transmitted to third parties, in whole or in part, without the written authorisation of the machine Manufacturer.

Plant manufacturer
PEGORARO GAS TECHNOLOGIES S.r.l.
 Premises: via Meucci, 77
 36057 Arcugnano (Vicenza)

	TECHNICAL DOCUMENTATION In conformity with Directive 2014/68/CE	Family EV2
	USE AND MAINTENANCE INSTRUCTIONS	Doc. MU EV2 - Rev.03
		Pagina 6 di 38

1.4 DESCRIPTION OF PICTOGRAMS AND SYMBOLS

In the manual the following symbols are employed to highlight particularly important instructions and warnings:



ATTENTION

This symbol indicates safety standards for the operator and/or any persons exposed



WARNING:

This symbol indicates that there is the possibility of causing damage to the product and/or its components.



NOTE:

This symbol indicates useful information



ATTENTION

Read the instruction manual before doing anything

MANDATORY AND REQUIRED

Use personal safety equipments and tools



Helmet

Ears protection

Safety shoes

Gloves

Mask

Glasses

Overalls

Safety harness



DANGER

Explosion with the presence of shrapnel under pressure



DANGER

Potentially explosive atmosphere



DANGER

Voltage



DANGER

Burns

	TECHNICAL DOCUMENTATION In conformity with Directive 2014/68/CE	Family EV2
	USE AND MAINTENANCE INSTRUCTIONS	Doc. MU EV2 - Rev.03 Pagina 7 di 38

1.5 APPLIANCE INTENDED PURPOSE

The vaporizer has been devised, designed and manufactured to be installed in LPG vaporizing and decompression stations for heating and vaporizing liquid LPG passing through the plant, into has before this is decompressed.

PEGORARO GAS TECHNOLOGIES s.r.l. declines all responsibility for any damage to things or persons in the event of:

- Handling, installation, commissioning, maintenance of the individual installed appliances and scrapping by non-qualified personnel;
- improper use of the plant;
- modifications, welding or damage;
- failure to comply with the current applicable safety standards and health and safety laws and regulations.
- operation at temperature and pressure higher than those specified in the rating plate;
- alteration or removal of safety protection components (electrical, electronic, electro-pneumatic, electro-mechanical).
- removing, painting over or covering plant identification plates and warning symbols.
- installation errors;
- lack of proper maintenance;
- failure to comply with the content of this user manual

2. TECHNICAL CHARACTERISTICS

The data are also given on the rating plate fixed to the vaporizer (see fig. 2-1)



Fig. 2.1

The tables and figures given below illustrate the technical characteristics of the vaporizer:

ECOVAP Hot Water Version

	ECOVAP 50A	ECOVAP 100A	ECOVAP 200A	ECOVAP 300A	ECOVAP 500A	ECOVAP 750A	ECOVAP 1000A
A [mm]	850	1350	1350	1230	1200	1300	1300
B [mm]	282	282	282	294	380	490	490
C [mm]	318	318	318	330	390	410	410
D [mm]	324	324	324	410	550	750	750
WEIGHT [kg]	100	130	130	170	380	430	430
WATER [lts]	50	85	85	90	175	340	340
DN GAS IN/OUT	1"x1" ANSI300	1"x1" ANSI300	1"x1" ANSI300	1"x1" ANSI300	1"x2" ANSI300	2"x2" ANSI300	2"x2" ANSI300
DN WATER IN/OUT	3/4"	3/4"	3/4"	1"	1"1/2	1"1/2	1"1/2
PS GAS SIDE	20 bar	20 bar	20 bar	20 bar	20 bar	20 bar	20 bar
PS WATER SIDE	3 bar	3 bar	3 bar	3 bar	3 bar	3 bar	3 bar
PT GAS SIDE	28,6 bar	28,6 bar	28,6 bar	28,6 bar	28,6bar	28,6 bar	28,6 bar
PT WATER SIDE	4.3 bar	4.3 bar	4.3 bar	4.3 bar	4.3 bar	4.3 bar	4.3 bar
TS GAS SIDE	-40 / + 120 °C						
TS WATER SIDE	-10 / + 105 °C						
STANDARD	European Directive 2014/68/EU PED, ISPEL VSR-M-S Ed.99 Rev.95 completed with EN13445-5, ASME VIII Div.1						

Tab. 2.1

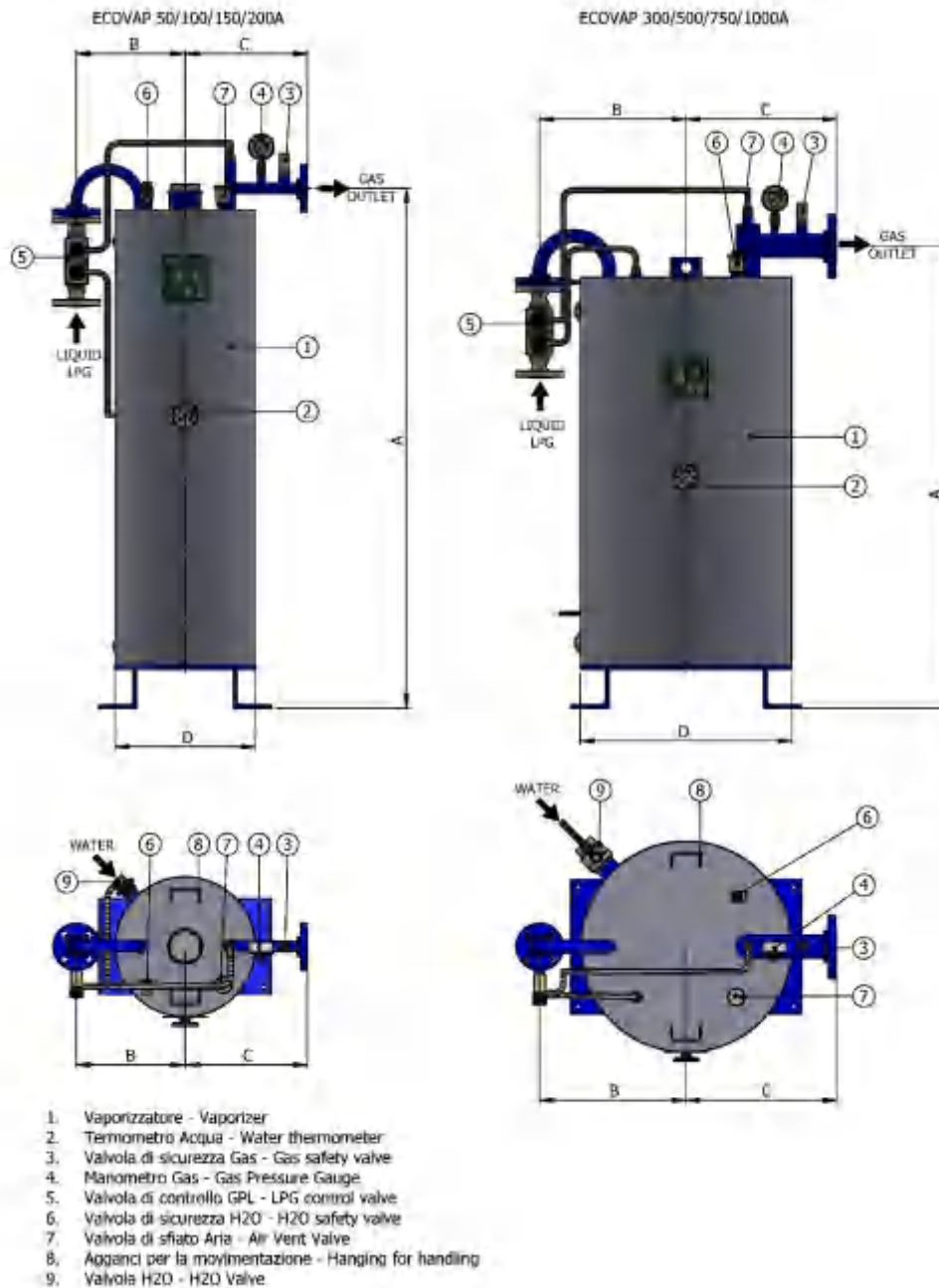

ECOVAP 50A-100A-200A

ECOVAP 300A-500A-750A-1000A

Fig. 2.2

	TECHNICAL DOCUMENTATION In conformity with Directive 2014/68/CE	Family EV2
		Doc. MU EV2 - Rev.03
	USE AND MAINTENANCE INSTRUCTIONS	Pagina 10 di 38

The tables and figures given below illustrate the technical characteristics of the vaporizer:

ECOVAP hot water version with electric preheating

	ECOVAP 50E	ECOVAP 100E	ECOVAP 150E	ECOVAP 200E	ECOVAP 300E	ECOVAP 500E	ECOVAP 750E
A [mm]	850	1350	1350	1350	1350	1530	1530
B [mm]	282	282	282	374	374	730	850
C [mm]	318	318	318	410	410	1250	1250
D [mm]	324	324	324	508	508	550	550
WEIGHT [kg]	110	140	140	240	240	315	315
WATER [liters]	50	85	85	200	200	465	465
DN GAS IN/OUT	1"x1" ANSI300	1"x1" ANSI300	1"x1" ANSI300	1"x1" ANSI300	1"x2" ANSI300	2"x2" ANSI300	2"x2" ANSI300
POWER [kW]	8	16	24	32	48	80	120
VOLTAGE	380V	380V	380V	380V	380V	380V	380V
PS GAS SIDE	20 bar	20 bar	20 bar	20 bar	20 bar	20 bar	20 bar
PS WATER SIDE	ATM	ATM	ATM	ATM	ATM	ATM	ATM
PT GAS SIDE	28,6 bar	28,6 bar	28,6 bar	28,6 bar	28,6 bar	28,6bar	28,6 bar
PT WATER SIDE	1,43 bar	1,43 bar	1,43 bar	1,43 bar	1,43 bar	1,43 bar	1,43 bar
TS GAS SIDE	-40 / +120 °C						
TS WATER SIDE	-10 / +105 °C						
STANDARD	European Directive 2014/68/EU PED, ISPEL VSR-M-S Ed.99 Rev.95 completed with EN13445-5, ASME VIII Div.1 Other Standards applied: European Directive 94/9/EC ATEX (electrical heater)						

Tab. 2.2

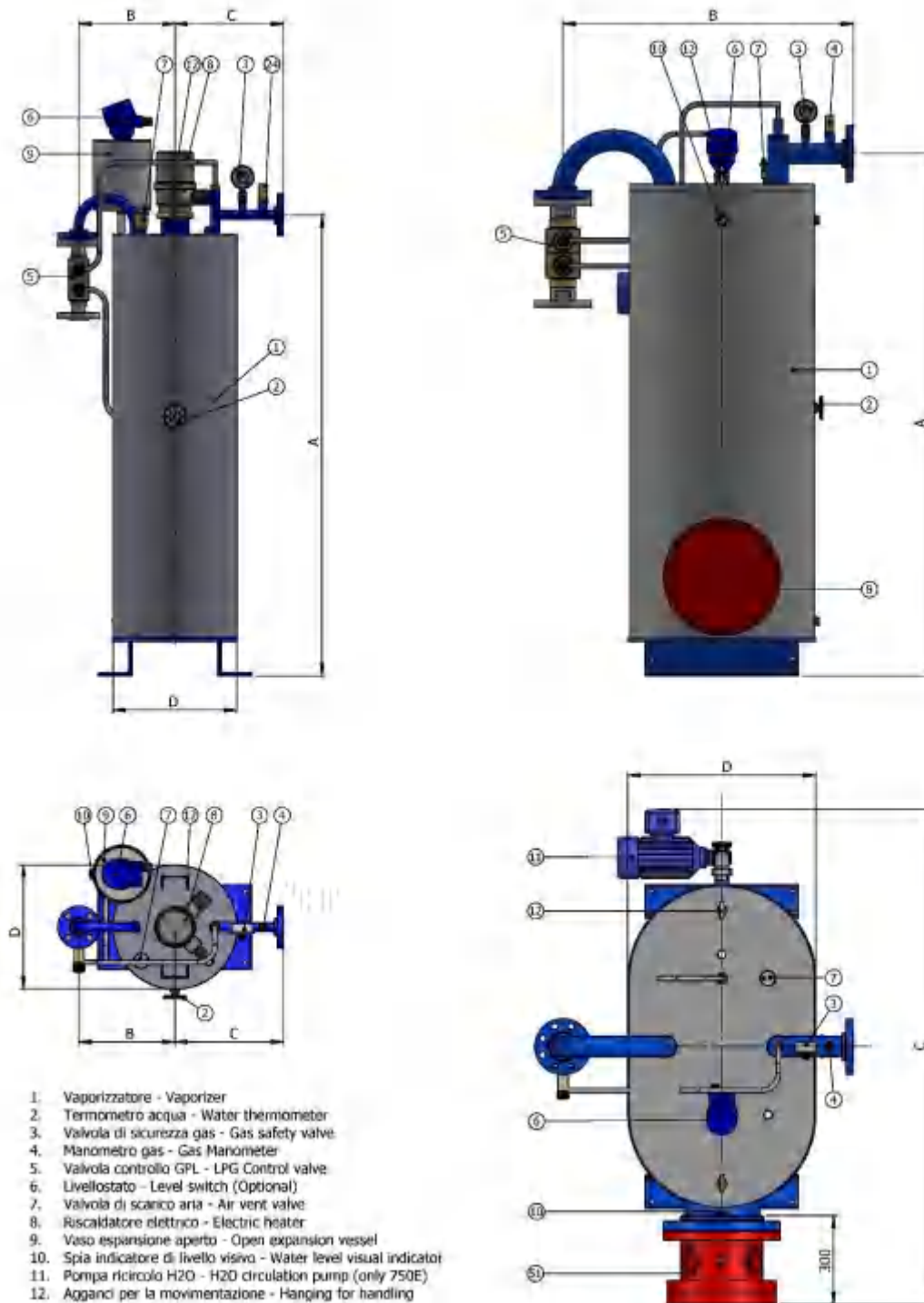

ECOVAP 50E-100E-150E-200E-300E

ECOVAP500E-750E

Fig. 2.3

	TECHNICAL DOCUMENTATION In conformity with Directive 2014/68/CE	Family EV2
	USE AND MAINTENANCE INSTRUCTIONS	Doc. MU EV2 - Rev.03
		Pagina 12 di 38

3. HANDLING

Handling and transport operations must be carried out by qualified personnel. Do not damage the vaporizer during transport and handling.

The vaporizer has been supplied complete with a support base, a fork-lift truck with a lifting capacity suitable for the weight to be lifted must be used.

To handle it, lift it by the base or sling it with cable or ropes having lifting capacity suitable for the weight to be supported, which must be placed around the circumference or on inlet and outlet flanged gas piping, taking care not to damage the insulation.



ATTENTION

It is good practice to use lifting equipment with sufficient lifting capacity to hold the weight of the plant increased by about 20%.

WARNING

The plant is supplied painted or galvanised. However, accidental knocks during handling and installation could cause loss of efficiency of the paint or zinc coating, triggering a slow process of oxidation (rust), so it is recommended to restore the original protection with paint or cold zinc coating.

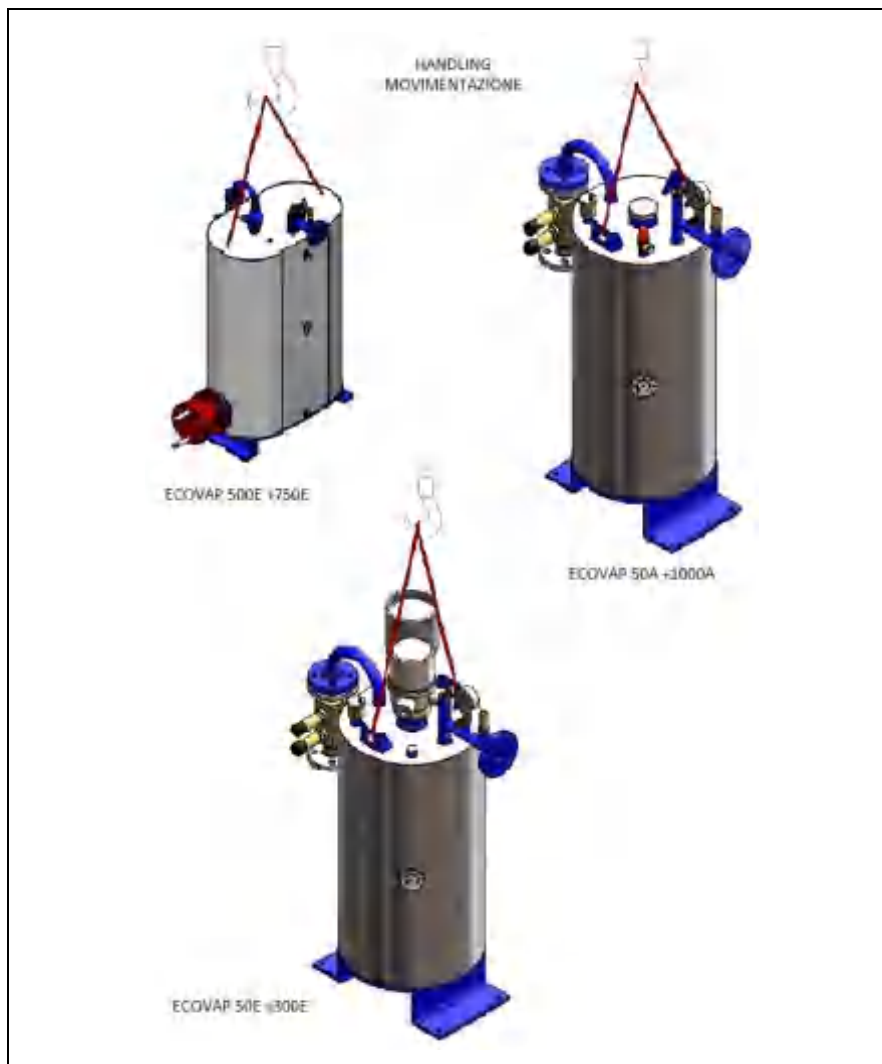



Fig. 3.1

	TECHNICAL DOCUMENTATION In conformity with Directive 2014/68/CE	Family EV2
	USE AND MAINTENANCE INSTRUCTIONS	Doc. MU EV2 - Rev.03 Pagina 13 di 38

4. INSTALLATION

- The Ecovap vaporizer must be installed VERTICALLY
- Do not subject the plant to static or dynamic loads or to bending movements.
- The installation must be carried out by suitable personnel.
- The plant is delivered to the buyer after having carried out the inspection and seal tests: however, some connections could work loose during transport and handling, so it is necessary to:
 - check the mechanical connection between the individual parts;
 - Carry out a pressure test with air and check any leaks with a suitable revealing medium (we suggest soapy water) on both the flanges and the couplings.



ATTENTION

For correct and safe use an adequate earth connection must be provided using the hole on the support feet of the vaporizer, indicated by the symbol:



PRECAUTIONS

The electric resistances have an explosion-proof housing with IP65 level. The vaporizer can be used outdoors but it is advised to protect it with canopy or with a cabinet.

The heat exchanger has been calculated so as to guarantee the flow under normal operating conditions: but if it is located in sites subject to low temperatures, heat loss could cause diminished performance of the fitted equipment.

Consequently we highly recommend that the vaporizer be protected by a specific cubicle or closed environment, equipped with a specific ventilation system and if possible insulated.

	TECHNICAL DOCUMENTATION In conformity with Directive 2014/68/CE	Family EV2
		Doc. MU EV2 - Rev.03
	USE AND MAINTENANCE INSTRUCTIONS	Pagina 14 di 38

4.1 VERSION WITH ELECTRIC PREHEATING

4.1.1 ELECTRICAL CONNECTION

(Electrical panel for safe area with a degree of protection of IP65)

- Open the electric panel installed in a “Safe Zone”.
- Wire up the cable for connecting the panel to the electrical resistance, passing the cable through the provided hole on the panel and fix the cable with a cable clamp. The terminals of the electrical heater are located inside the Eexd housing under the thermostats.

To access the terminals:

1. Unscrew the housing lid
2. Unscrew the two nuts that secure the bracket holding the thermostats
3. Extract the thermostats from their sheath

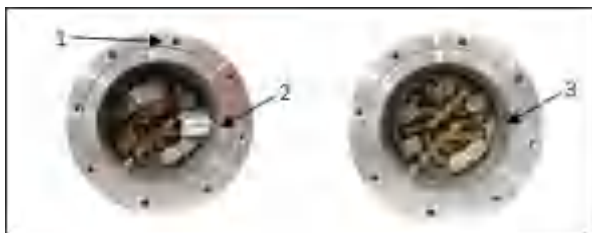

Fig. 4.1
Versione flangiata



Fig. 4.2
Versione filettata

- Once the connection has been made, repeat the above operations in inverse order.
- Connect the cable between the electrical panel and the thermostats, inserted in the Eexd casing of the electrical heater, passing the cable through the provided hole on the panel and fixing it with a cable clamp (cable recommended for a distance of 10-15 m type FG7 3x1.5).
- Connect the electric power supply cable to the panel, passing the cable through the hole provided on the panel.
- For the connections follow the instructions provided in the enclosed diagrams.
- There are two cable entries in the electrical resistance casing:
 - The larger one for connecting the supply cable
 - The smaller one for connecting the cables of the thermostats

The connections between panel and the electric resistance must be made with flexible cables of type FG7 4Gxmmq (see following table for mm²).



We remind you that both the cable and its respective cable clamp must comply with the standards for plants in areas subject to explosion or fire hazard.

The cable section varies according to the installed power and to the distance between the vaporizer and the electric control board.

For the cable sections to be used, follow the table below:

**DIMENSIONS OF ELECTRICAL CABLES CONNECTING
OF THE VAPORIZER WITH THE ELECTRICAL PANEL**

LPG Flow Kg/h	Power kW	Cable glands	Electrical connection	Voltage Volt	Intensity Ampere	Cable section mm ² (1 cable)			
						Length. 30 m	Length. 60 m	Length. 100 m	Length. 150 m
50	8	1" NPT	Three-phase	380/400	12	2.5	4	6	10
100	16	1" NPT	Three-phase	380/400	24	4	6	10	16
150	24	1" NPT	Three-phase	380/400	36	6	10	16	25
200	32	2 x 1" NPT	Three-phase	380/400	49	10	16	25	35
300	48	2 x 1" ½ NPT	Three-phase	380/400	73	10	25	35	50
500	80	2 x 1" ½ NPT	Three-phase	380/400	122	16	35	50	95
750	120	2 x 1" ½ NPT	Three-phase	380/400	182	25	50	75	120
						Cable section mm ² (2 cables)			
50						-			
100						-			
150						-			
200						4	6	10	16
300						10	16	25	35
500						10	16	35	50
700						16	35	50	75

Tab. 4.1

Note:

The calculated section is indicative and refers to multicore cables with a voltage drop of ≤2 % for three-phase and ≤4 % for single-phase.

The indicated current intensity refers to single-phase.

In case of an electric resistance with a power above 32Kw it is advised to use of nos. 2 supply cables in order to maintain reduced cable sections.



Do not turn electrical resistance head before disconnecting the thermostats. If you turn head without disconnecting thermostats you will break the probes.



Close the door of the electric panel with the key provided and put it in a safe place.

	TECHNICAL DOCUMENTATION In conformity with Directive 2014/68/CE	Family EV2
	USE AND MAINTENANCE INSTRUCTIONS	Doc. MU EV2 - Rev.03 Pagina 16 di 38

4.1.2 ELECTRICAL CONNECTION

(Eexd electrical panel already fitted to the vaporizer)

If the vaporizer is already fitted with a connected Eexd electrical control panel you only have to power the panel with an electrical energy source, usually three-phase 380/400V.

4.1.3 WATER LEVEL SWITCH (OPTIONAL)

It is possible to install an electromagnetic level switch for water, with a float and a “Reed” contact, complete with an aluminium Eexd watertight casing, allowing to monitor the water level inside the vaporizer.

Follow the detailed instructions for the connection provided in the manual.

If the level switch is not Eexd, but Ex-ia, the electric power supply has to come from a galvanic isolator.



WARNINGS

The position of the level switch must be more than 5 cm from the upper heating limit of the electric resistances.

4.1.4 FILLING THE WATER CIRCUIT

Vaporizers from 50E to 300E are available equipped with an open expansion tank, to allow water to flow out when its temperature increases.

To fill up the water circuit follow the instructions below (see also fig. 4.2):

- Remove the expansion tank cap. If the vaporizer is fitted with a vent valve slacken its black cap.
- Pour water into the expansion tank
- Fill up the whole heat exchanger until the visual water level indicator installed on the expansion tank is covered.
- Replace the expansion tank cap.

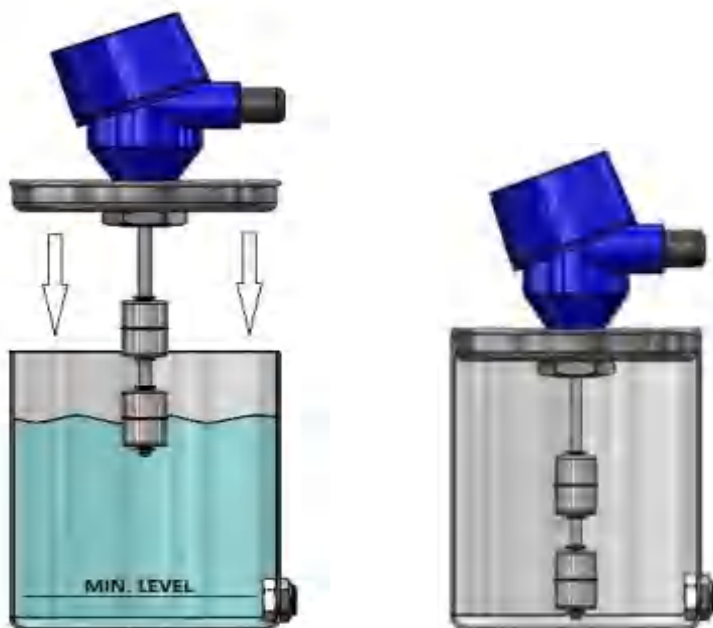

Do not exceed the 75% of the tank

Any excess water must be removed by opening the discharge valve fitted at the bottom of the vaporizer itself

FILLING THE WATER CIRCUIT RIEMPIMENTO CIRCUITO ACQUA

ECOVAP 500E + 750E

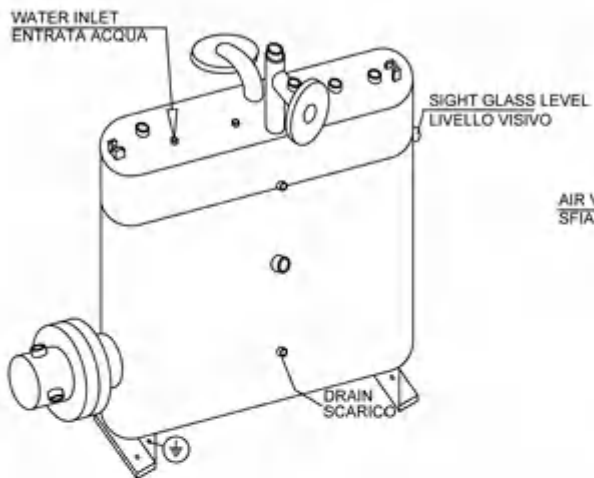

ECOVAP 50A +1000A

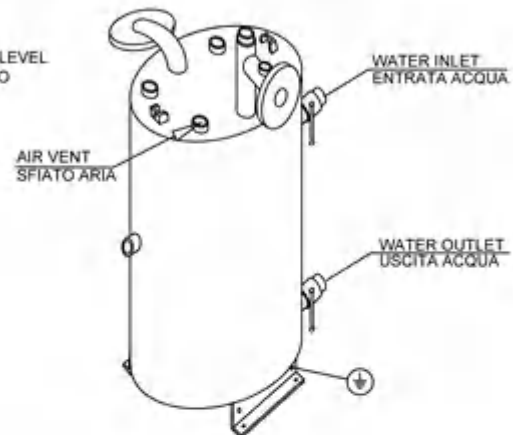

ECOVAP 50E + 300E

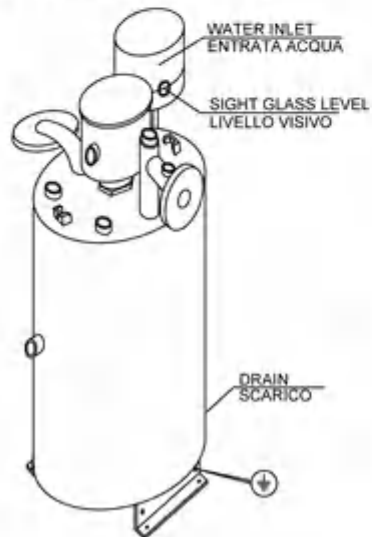

Fig. 4.2

Vaporizers from 500E to 750E have an internal expansion tank: in fact the water circuit is at ambient pressure. So as to let out the water (steam) when the temperature increases, the vaporizer must be filled up with water half way up to the visual level indicator. The vaporizer water is also fitted with an overflow plug labelled as “maximum water level”.

To fill up the water circuit follow the instructions below (fig. 4.2):

- Remove the filling cap on the top of the vaporizer labelled “Water Inlet”.
- Remove the overflow plug on the side of the vaporizer, (the one labelled as maximum and minimum water level). If an air vent valve is present, remove or loosen its black cap.
- Fill with water.
- The level required for correct operation is when water reaches the visual indicator and starts flowing out from the overflow plug on the side of the vaporizer.
- Replace the filling cap and the overflow plug

The vaporizers have different capacities on the water side: see tables 2-1 and 2-2.



WARNINGS

It is recommended to use water coming from the city waterworks, not sourced from water wells or production processes. Using aggressive water could increase the possibility of creating oxides inside the vessel, with the risk of corrosion.



In particularly cold places the water may be diluted with antifreeze. It is recommended to use only “ETHYLENE GLYCOL” as antifreeze as it guarantees complete WATER-SOLUBILITY and can be bought from specialised dealers. The use of ordinary antifreeze is not advised as it is aggressive for the circuit itself and favours the phenomenon of stratification in the case of plant stoppage. This means that the water moves with difficulty when the plant is switched on again.

See the chart below for percentage of ethylene glycol:

Minimum Temperature °C	Ethylene Glycol Percentage
0	0
-5	8
-10	20
-15	28
-20	32
-25	40
-30	45
-35	48

Tab. 4.2

4.2 HOT WATER VERSION

4.2.1 CONNECTIONS

The Vaporizer must be supplied with hot water coming from an external boiler.



WARNING

The boiler flow rate must be such as to cover the amount of calories required by the declared flow rate of the vaporizer, as indicated on the vaporizer rating plate, necessary to supply hot water at a temperature of 70°C.

Connect the delivery and return boiler water lines by means of the taps fitted to the vaporizer (see Fig. 2.2)

4.2.2 BOILER REQUIREMENTS

The boiler that supplies hot water to the vaporizer must have the following technical characteristics:

Ecovap		50A	100A	200A	300A	500A	750A	1000A
Water flow	[m ³ /h]	1.0	1.5	3.0	4.5	7.5	12.0	15.0
Power	[kW]	8	15	30	45	76	113	151
Inlet Temp.	[°C]	75	75	75	75	75	75	75
Outlet Temp.	[°C]	67	67	67	67	67	67	67
Pressure drop	[bar]	0.04	0.06	0.10	0.21	0.26	0.29	0.31

Tab. 4.3



WARNING

If you respect these points, as well as the others illustrated, you will have the maximum capacity of the heat exchanger at your disposal. Failure to satisfy these requirements causes a notable and appreciable drop in the total flow rate of the vaporizer, causing difficulties in starting up and in normal operation of the vaporizer. The vaporizer has been designed to supply the adequate flow rate in normal operating conditions. However, if it is located in sites with a low ambient temperature, heat loss could cause reduced performance. To avoid situations of this kind it is highly suggested to install the vaporizer in an insulated cabinet



ATTENTION

The temperature of the water circuit could cause injury to personnel if they come in contact with hot parts, so the use of insulation material protection is recommended. The vaporizer and the boiler must be installed by qualified personnel.

4.2.3 FILLING THE WATER CIRCUIT

Refer to section 4.2.1

5. COMMISSIONING

	TECHNICAL DOCUMENTATION In conformity with Directive 2014/68/CE	Family EV2
	USE AND MAINTENANCE INSTRUCTIONS	Doc. MU EV2 - Rev.03
		Pagina 20 di 38



ATTENTION

During the commissioning phase, absolutely avoid smoking and using naked flames, explosion hazard. Failure to observe these conditions may cause severe damage to persons and to the plant.

- Before commissioning, we recommend checking that the operating conditions conform with the characteristics on the appliance rating plate. (Fig. 2.1)
- Before carrying out any maintenance work it is important to ensure that the upstream and downstream stop valves have been closed and that the pressure in the lengths of pipe between the two valves has been discharged.
- Ensure that the water circuit has been correctly installed and primed (hot water version) or that the vaporizer has been filled with water

5.1 VERSION WITH ELECTRIC PREHEATING

- Ensure that the electrical connections between the resistance and of the thermostats have been made correctly, refer to section 4.1.1
- Unscrew the resistance casing: inside there are 2 thermostats. One operating thermostat (1) and one safety thermostat (2). The latter has a little green button for manual resetting (3).
- Check the proper operation of the thermostat when switching on and off: by rotating the thermostat regulation you should hear a “click” guaranteeing the correct operation of the thermostat; if you cannot hear the “click” it means that the thermostat is not operating correctly.
- Set the operating thermostat at 70°C.
- Set the safety thermostat at 95°C.
- Press the green button to reset the thermostat.
- Close the resistance casing.
- Turn on the power supply of the electrical panel (“voltage” light on and “resistance on” lamp on)
- Wait 15/20 minutes until the water reaches the required temperature (“heater off” lamp on): check the water temperature on the vaporizer thermometers.
- Check that there are no leaks in the water circuit gaskets.

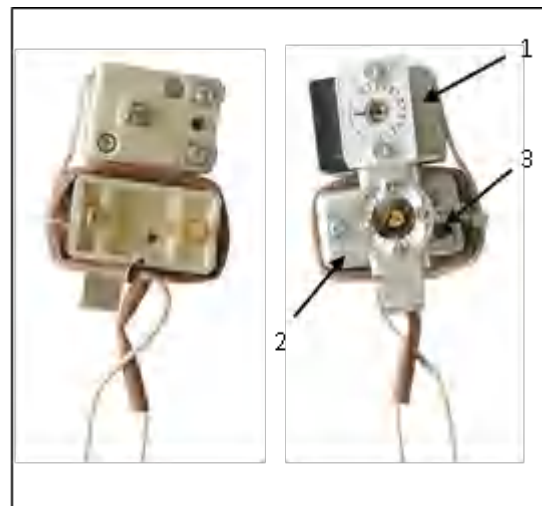

1. Working thermostat
2. Safety thermostat
3. Reset bottom

Fig. 5.1

	TECHNICAL DOCUMENTATION In conformity with Directive 2014/68/CE	Family EV2
	USE AND MAINTENANCE INSTRUCTIONS	Doc. MU EV2 - Rev.03 Pagina 21 di 38



ATTENTION

When starting up for the first time the hot water will take 30/60 minutes (according to the water volume) to reach the required temperature to open the control valve.

After this phase open the liquid gas inlet valve very slowly. Opening this valve too quickly may cause irreversible damage to the vaporizer, for instance causing the input of liquid LPG at low temperature causing freezing and the consequent breakage of the vaporizer heat exchange coil: this is why great attention must be paid when carrying out this operation. This situation could be extremely dangerous and may lead to the explosion of the vaporizer.

- Liquid LPG enters the vaporizer automatically.



ATTENTION

If gas does not start to flow inside the coil, a fine adjustment of the control valve screws is required. Consequently:

- slowly tighten (clockwise movement) the regulation screw fitted under the black plastic protections (see chap. 8.3)
 - do not turn it more than half a turn
 - start turning the first regulation screw clockwise, the WATER SIDE one (closest to the inlet)
 - should this not be enough, also turn the second regulation screw, the GAS SIDE one, always not more than half a turn.
- Check that there are no leaks in the gas circuit connections.
 - Slowly open the downstream valve towards the reducers.
 - It is now possible to start gas consumption.



ATTENTION

For the first hours of operation it is recommended to increase the withdrawal of gas very gradually, so as to allow the activation of the movement of the aqueous solution in the circuit, and to allow the regulating system to adapt to the working conditions.

5.1.1 CHECKS AND CONTROLS

- Check the temperature of the water, because the flow rate of the gas in the vaporizer self-adjusts according to the difference in temperature of the aqueous solution between the upper and the lower level of the vaporizer.
- If the water temperature in the lower part of the vaporizer falls below 50°C, the control valve closes.
- The water is kept at the desired temperature by the regulation thermostat set at 70°C which activates or deactivates the resistance.
- If the regulation thermostat breaks down, a second thermostat TS, set at 95°C, intervenes and deactivating the resistance. This thermostat is manually reset, it is reset manually as in fig. 5.1.
- It is recommended to check the water level periodically and refill when necessary.

	TECHNICAL DOCUMENTATION In conformity with Directive 2014/68/CE	Family EV2
	USE AND MAINTENANCE INSTRUCTIONS	Doc. MU EV2 - Rev.03 Pagina 22 di 38

5.2 HOT WATER VERSION

- Start up the boiler.
- Ensure that the vaporizer inlet and outlet valves are completely closed.
- Ensure that the water circuit has been completely filled up.
- Wait for the water temperature to reach the required value, reading it on the thermometer on the fitted on the vaporizer.
- Check that there are no leaks in the water circuit.



ATTENTION

At this point open the liquid gas inlet valve very slowly. Opening this valve too quickly may cause irreversible damage to the vaporizer, for instance causing the input of liquid LPG at low temperature causing freezing and the consequent breakage of the vaporizer heat exchange coil: this is why great attention must be paid when carrying out this operation.

- Liquid LPG enters the vaporizer automatically. You can read the pressure on the pressure gauge fitted on the vaporizer outlet.



ATTENTION

If gas does not start to flow inside the coil, a fine adjustment of the control valve screws is required. Consequently:

- slowly tighten (clockwise movement) the regulation screw fitted under the black plastic protections
 - do not turn it more than half a turn
 - start turning the first regulation screw clockwise, the WATER SIDE one (closest to the inlet)
 - should this not be enough, also turn the second regulation screw, the GAS SIDE one, always not more than half a turn.
- Check that there are no leaks in the gas circuit gaskets.
 - Slowly open the downstream valve towards the reducers.
 - It is now possible to start gas consumption.



ATTENTION

For the first hours of operation it is recommended to increase the withdrawal of gas very gradually, so as to allow the activation of the movement of the aqueous solution in the circuit, and to allow the regulating system to adapt to the working conditions.



ATTENTION

If the vaporizer outlet gas temperature is above 60°C using the resistance operating thermostat lower its operating temperature to about 5/10°C (see chap. 5.1 for the thermostat settings.)

	TECHNICAL DOCUMENTATION In conformity with Directive 2014/68/CE	Family EV2
		Doc. MU EV2 - Rev.03
	USE AND MAINTENANCE INSTRUCTIONS	Pagina 23 di 38

5.2.1 CHECKS AND CONTROLS

- Check the temperature of the water, because the flow rate of the gas in the vaporizer self-adjusts according to the difference in water temperature between the upper and the lower level of the vaporizer.
- If the water temperature in the lower part of the vaporizer falls below 50°C, the control valve closes.

5.3 GENERAL WARNINGS FOR THE CORRECT OPERATION OF THE VAPORIZER

- Once the vaporizer has been put into operation, switch it off only in the case of maintenance operations or for long periods of inactivity of the downstream reduction unit.
- It is advisable to leave the vaporizer on overnight or at the weekend, because consumption is negligible, and it avoids having to repeat the switch-on procedures.
- When switching off the plant, always close the stop valve on the vaporizer inlet, located on the vaporizer inlet.
- Before starting up the plant again it is indispensable to discharge the liquid gas downstream from the vaporizer, which has formed after switching off the plant.
- The filter on the inlet (incorporated in the thermostatic valve) avoids the entry of impurities which could settle on the seat of the valve (causing leaks of liquid gas). So it must be cleaned as indicated in chap. 8.1)
- When LPG is very dirty it is recommended to install an additional filter, before the control valve (liquid phase. vaporizer inlet).

	TECHNICAL DOCUMENTATION In conformity with Directive 2014/68/CE	Family EV2
	USE AND MAINTENANCE INSTRUCTIONS	Doc. MU EV2 - Rev.03
		Pagina 25 di 38

			If all valves are open and water is at the correct temperature but still there is no gas flow, it means that the control valve has got blocked and it needs a fine setting adjustment. Proceed as indicated in Chap.5.1 or 5.2
--	--	--	--

7. HOW THE CONTROL VALVE WORKS (called the “VALVE”) AND HOW TO SET IT

7.1 HOW THE VALVE WORKS

Our Ecovap vaporizers are fitted with a double-safety thermostatically operated control valve that detects the temperature inside the vaporizer and accordingly regulates the inlet flow of gas:

- the 1st safety operates depending on the water side temperature.
- the 2nd safety operates depending on the gas side temperature.

This valve has a completely mechanical operation: it does not require any electrical connections.

7.2 VALVE SETTING

The pressure and the propane/butane mixture (LPG) that is to be used define the best setting of the valve. Each valve is equipped with setting screws, by means of which the temperature setting can be regulated (see figure 7.1).

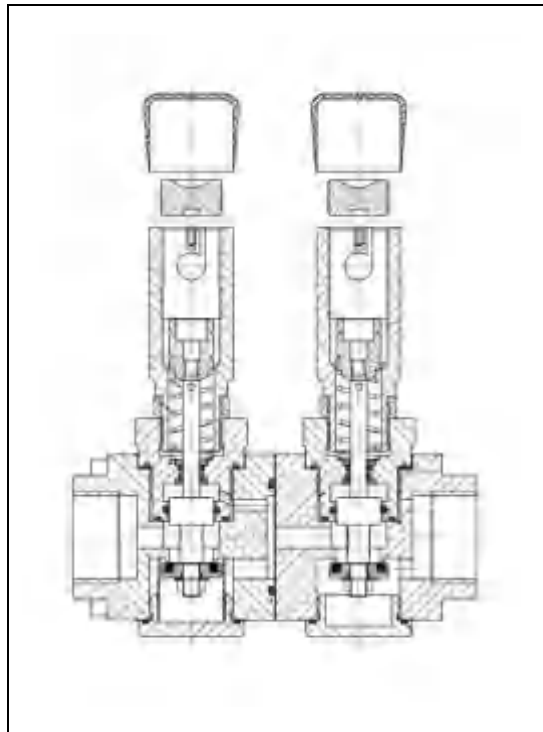



Fig. 7.1



ATTENTION

Do not touch the setting of the screws. Their setting position must not be modified. It is our duty to take care of valve settings in our laboratory, by tightening or slackening the screw the setting will

	TECHNICAL DOCUMENTATION In conformity with Directive 2014/68/CE	Family EV2
	USE AND MAINTENANCE INSTRUCTIONS	Doc. MU EV2 - Rev.03 Pagina 26 di 38

be altered for ever. This manoeuvre may affect the correct operation of the vaporizer, putting it in great danger.

7.2.1 CHECKS AND CONTROLS

Each vaporizer is delivered with its valve suitably set according to the composition of the mixture of gas of the final user. This information must be supplied by the customer, who is considered liable for the provided data.

The 1st safety operates depending on the water temperature inside the vaporizer, the 2nd safety operates depending on the temperature of the gas flowing out of the vaporizer.

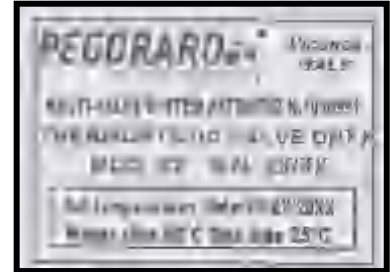

The 1st safety is usually set at a temperature between 50°C and 60°C. The 2nd safety is set according to the operating conditions.

The valve is delivered with a label indicating the setting temperatures.

LPG enters its gaseous state at different temperatures, depending on the pressure and the propane/butane mixture: this is why the second safety setting must be dedicated. The following table shows how the gasification temperature depends on the pressure and the propane/butane mixture.

The 2nd valve safety has a wide setting range, from 20°C to 50°C, which covers all the LPG applications and operating conditions.

If the LPG composition is unknown, we use standard settings (55°C for water and 25°C for Gas)

Temperature [°C]	Propane-butane mixture											
	Tank Pressure [barg]	100%	90/10	80/20	70/30	60/40	50/50	40/60	30/70	20/80	10/90	0%
2		-14	-6	0	5.5	10	14	17.5	21.5	24.5	28	31
4		1	9	15.5	21	25.5	30	34	38	42	45.5	49
6		12	20	27	32.5	37.5	42	46.5	51	55	59	62.5

Tab. 7.1



ATTENTION

For safety reasons it is important to know the following characteristics of the Lpg:

- maximum LPG pressure during the year;
- maximum butane percentage in the LPG mixture which is to be used.

	TECHNICAL DOCUMENTATION In conformity with Directive 2014/68/CE	Family EV2
	USE AND MAINTENANCE INSTRUCTIONS	Doc. MU EV2 - Rev.03 Pagina 28 di 38

8. MAINTENANCE

LPG is not a clean gas: usually it contains particles of dirt and oily substances that can cause the vaporizer to malfunction. If the gas is correctly filtered upstream, the vaporizer generally does not require any specific maintenance.

In the event of faulty operation or of a plant breakdown, before beginning any maintenance operation, switch off the power on the electric panel (version with electric preheating) or close down the boiler (hot water version), close the stop valve upstream from the vaporizer and discharge any gas left in the piping.

If the flow rate of the vaporizer decreases it is necessary to carry out maintenance. The components that require maintenance are in particular the inlet filter (housed inside the valve), the valve and the heat exchanger.

8.1 FILTER FITTED ON THE VALVE WATER SIDE

It is recommended to clean up the filter at least once a year. If the filter is particularly dirty or clogged, it is advisable to clean it more frequently.

Check the filter also when the vaporizer does not work properly, that is when its flow rate decreases.

- Switch off the vaporizer and remove all the LPG from inside:
 - Ensure that all the valves upstream and downstream from the vaporizer are closed.
 - Remove the pressure gauge.
 - Predisporre un tubo di corretta lunghezza nella valvola di intercettazione manometro e portarlo lontano dell'area del vaporizzatore

Open the valve to eliminate all the residual gas.

- Using a size 36 spanner unscrew the cap under the water side safety valve (see Chap. 8.3)
- Remove the stainless steel filter from inside.
- Clean the filter with compressed air or with solvent for hydrocarbons
- Change the filter if necessary.
- Refit the cap.
- Close the pressure gauge stop valve, remove the pipe and refit the pressure gauge

8.2 EXCHANGER

The Ecovap heat exchanger is designed to work with a minimum maintenance.

It is recommended to clean the coil and the shell every 3-5 years, in order to avoid a decrease of the exchanging surface due to scaling of impurities and oily substances.

1. Switch off the vaporizer and remove all the LPG from inside.
2. Ensure that all the valves upstream and downstream from the vaporizer are closed.
3. Remove the pressure gauge.
4. Prepare a pipe of suitable length to connect to the pressure gauge stop valve for in order to lead far from the area in which the vaporizer is installed;
5. Open the valve to eliminate all the residual gas.
6. Remove the screws connecting the flange on the inlet and outlet.
7. Extract the vaporizer from its position.
8. Run solvent for hydrocarbons through the coil to remove all impurities from inside.
 - USE SCALE-REMOVING ACID compatible with the exchanger material (DISINEX diluted to 10%-20% with water) followed by a NEUTRAL neutralizer
 - The solvent must be introduced using suitable and compatible means (e.g. DISINEX PUMP 18K)
9. Repeat the operations in inverse order, taking care to change the flange gaskets.

	TECHNICAL DOCUMENTATION In conformity with Directive 2014/68/CE	Family EV2
	USE AND MAINTENANCE INSTRUCTIONS	Doc. MU EV2 - Rev.03 Pagina 29 di 38

8.3 CONTROL VALVE

If the gas is properly filtered, the valve does not require frequent maintenance.

Therefore it is recommended to clean the valve filter regularly. For the procedure, see par. 8.1.





WARNING

If when carrying out the regular filter maintenance you observe that even the other components are dirty, it is recommended to clean all the other valve components or at least the most important ones such as the shutters.

8.3.1 ROUTINE MAINTENANCE







For all periodical valve servicing operations (all versions including the one with the viewer), that can be of use for checking the filter and shutter, refer to the following instructions (besides referring to the enclosed documents)



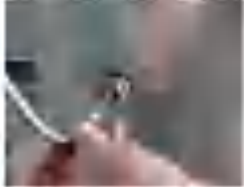



ensure that the stop valves, located upstream and downstream from the vaporizer, are in closed position	
remove the pressure gauge downstream from the vaporizer	
connect a pipe of suitable length to connect to the pressure gauge stop valve for in order to lead far from the area in which the vaporizer is installed	
Open the stop valve to eliminate all the residual gas.	
unscrew the cap on the base of the valve WATER SIDE using a size 36 spanner and remove the filter	
unscrew the WATER SIDE AND GAS SIDE shaft fixing nut using a size 10 spanner, remove the washer, remove the o-ring with the tool provided	
clean the mechanical components with a solvent such as Cyclohexane or, if required, replace the o-ring and the shutter (refit the or-rings using some grease)	
repeat the operations in reverse	
check that there is no leakage using air or nitrogen	
Check that there are no leaks on the gaskets or threads	

	TECHNICAL DOCUMENTATION In conformity with Directive 2014/68/CE	Family EV2
		Doc. MU EV2 - Rev.03
	USE AND MAINTENANCE INSTRUCTIONS	Pagina 30 di 38

8.3.2 SPECIAL MAINTENANCE

To properly disassemble the valve and replace its components refer to the following instructions (and also to the enclosed documents):

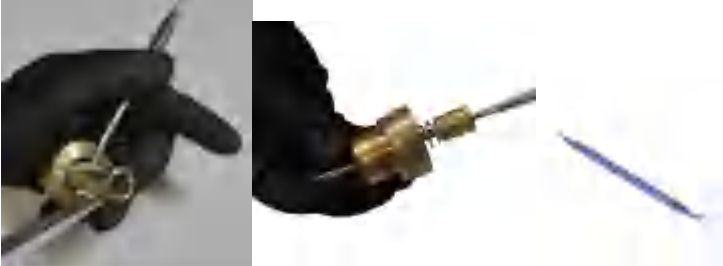
ensure that the stop valves, located upstream and downstream from the vaporizer, are in closed position	
remove the pressure gauge downstream from the vaporizer	
connect a pipe of suitable length to connect to the pressure gauge stop valve for in order to lead far from the area in which the vaporizer is installed	
unscrew the socket-head screw used to retain both sensor bulbs on the water side and gas side	
delicately extract the bulbs from their respective housing	
open the valve to eliminate all the residual gas and remove the control valve from its flanges	
mark a reference point of the position of regulation screw and using a calliper measure its height or depth bearing in mind that after maintenance the screw must return in its original position	
remove the four screws fitted on the body of the valve by means of a 5mm Allen wrench	 
unscrew the regulation screw using a screwdriver with a minimum 10 mm thickness and remove the bellows from inside by unscrewing the dowels using a 1.5mm Allen wrench	  

<p>unscrew the cap on the base of the valve WATER SIDE using a size 36 spanner and remove the filter</p>	
<p>unscrew the ring nut of the cylinder that houses the bellows using a size 27 spanner and remove it</p>	
<p>unscrew the shaft fixing nut using a size 10 spanner, remove the washer, remove the o-ring with the tool provided</p>	
<p>push the spring downwards and remove the shutter</p>	
<p>block the shaft with a pair of pliers or by hand and using a 10mm screwdriver unscrew the spring support</p>	
<p>extract the shaft</p>	
<p>clean the mechanical components with a solvent such as Cyclohexane or, if required, replace the o-ring and the shutter (refit the o-rings using some grease)</p>	

	TECHNICAL DOCUMENTATION In conformity with Directive 2014/68/CE	Family EV2
		Doc. MU EV2 - Rev.03
	USE AND MAINTENANCE INSTRUCTIONS	Pagina 32 di 38

repeat the operations in reverse order and bring the regulation screw back to its original position (tolerance +/- ¼ of a turn)	
check that there is no leakage using air or nitrogen	
Check that there are no leaks on the gaskets or threads	

	TECHNICAL DOCUMENTATION In conformity with Directive 2014/68/CE	Family EV2
	USE AND MAINTENANCE INSTRUCTIONS	Doc. MU EV2 - Rev.03
		Pagina 33 di 38

8.4 CONTROL VALVE WITH OPENING AND CLOSING VIEWER



If the gas is properly filtered, the viewer valve does not require frequent maintenance.





Therefore it is recommended to clean the valve filter regularly. For the procedure, see par. 8.1.



WARNING

If when carrying out the regular filter maintenance you observe that even the other components are dirty, it is recommended to clean all the other valve components or at least the most important ones such as the shutters.

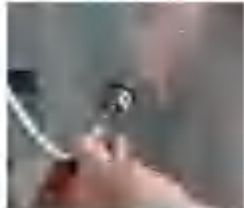
8.4.1 SPECIAL MAINTENANCE

ensure that the stop valves, located upstream and downstream from the vaporizer, are in closed position	
remove the pressure gauge downstream from the vaporizer	
unscrew the socket-head screw used to retain both sensor bulbs on the water side and gas side	 
delicately extract the bulbs from their respective housing	
mark a reference point of the position of regulation screw and using a calliper measure its height or depth bearing in mind that after maintenance the screw must return in its original position	









TECHNICAL DOCUMENTATION
In conformity with Directive 2014/68/CE

Family EV2



Doc.
MU EV2 - Rev.03

USE AND MAINTENANCE INSTRUCTIONS

Pagina 34 di 38

<p>remove the four screws fitted on the body of the valve by means of a 5mm Allen wrench)</p>	
<p>unscrew the regulation screw using a screwdriver with a minimum 10 mm thickness and remove the bellows from inside by unscrewing the dowels using a 1.5mm Allen wrench</p>	
<p>unscrew by hand the plastic cap supporting the viewer on the base of the valve</p>	
<p>unscrew the cap on the base of the valve using a size 36 spanner and remove the filter (filter present only on the valve WATER SIDE)</p>	
<p>unscrew the ring nut of the cylinder that houses the bellows using a size 27 spanner and remove it</p>	
<p>unscrew the shaft fixing extension screw using a size 13 box spanner, remove the washer, remove the o-ring with the tool provided</p>	
<p>push the spring downwards and remove the shutter</p>	



<p>block the shaft through the hole present on it by means of the o-ring tool or by hand and using a 10mm screwdriver unscrew the spring support</p>	
<p>extract the shaft</p>	
<p>clean the mechanical components with a solvent such as Cyclohexane or, if required, replace the o-ring and the shutter (refit the or-rings using some grease)</p>	
<p>repeat the same operations even on the second valve GAS SIDE</p>	
<p>repeat the operations in reverse order and bring the regulation screw back to its original position (tolerance +/- ¼ of a turn)</p>	
<p>check that there is no leakage using air or nitrogen</p>	
<p>Check that there are no leaks on the gaskets or threads</p>	



WARNING

It is highly recommended to clean the shutter after periods of vaporizer inactivity (even after a week) as the LPG deposits inside the valve with the risk of malfunction.



ATTENTION

During maintenance it is absolutely forbidden to smoke and use naked flames: explosion hazard.



Failure to observe this conditions may cause severe damage to persons and to the plant. The appliance and the connections will have to be controlled by qualified personnel. NEVER attempt to repair or restart the appliance on your own.

In case of improper repairs Pegoraro Gas Technologies will not be held responsible for any consequent damage.

	TECHNICAL DOCUMENTATION In conformity with Directive 2014/68/CE	Family EV2
	USE AND MAINTENANCE INSTRUCTIONS	Doc. MU EV2 - Rev.03 Pagina 36 di 38

8.5 SUMMARY OF THE MAINTENANCE TO BE CARRIED OUT

ADVISED MAINTENANCE PLAN
(Referred to optimal working conditions)

YEARLY	EVERY FIVE YEARS	ACCORDING TO THE OPERATING CONDITIONS (e.g. the quality of the liquid)
Clean the valve internal filter* Clean the valve shutter** <i>*if the filter is damaged replace it</i> <i>**if the shutter no longer seals replace it</i>	Clean the coil pipe	Clean the valve internal filter* Clean the valve shutter** Replace the o-ring*** Clean the coil pipe **** <i>*if the filter is damaged replace it</i> <i>**if the shutter no longer seals replace it</i> <i>***in the event of valve leaks</i>

WHAT TO USE

- *FOR THE FILTER, **SOLVENT FOR HYDROCARBONS (SEE CHAP. 8.1)**
- **FOR THE CONTROL VALVE AND ITS COMPONENTS, **CYCLOHEXANE (SEE CHAP. 8.3)**
- ***O-RING, **INDUSTRIAL GREASE (SEE CHAP. 8.3)**
- ****FOR THE COIL, **SOLVENT FOR HYDROCARBONS (SEE CHAP. 8.2)**



WARNINGS

THE VALVE MAINTENANCE MUST NOT BE CARRIED OUT ON THE SPOT, BUT IN SUITABLE LOCATIONS (LABORATORY or EQUIPPED WORKSHOP). ALWAYS KEEP A SPARE VALVE IN STOCK. OTHERWISE WE ADVISE YOU TO SEND THE VALVE TO PEGORARO GAS TECHNOLOGIES WHO WILL TAKE CARE OF THE MAINTENANCE ON YOUR VALVE.

9. DEMOLITION

At the end of its useful life, refer to the applicable regulations in the country of installation for its demolition or recycling.

10. ENCLOSED DOCUMENTATION

List of enclosures:

- Electrical resistance data sheet and manual (for Ecovap electric version);
- Electrical resistance wiring diagram (for Ecovap electric version);
- Electrical control panel wiring diagram (if included in the supply);
- Electrical resistance declaration of conformity (for Ecovap electric version);
- General Assembly of control valve;
- Exploded view of the control valve with each individual component.

	TECHNICAL DOCUMENTATION In conformity with Directive 2014/68/CE	Family EV2
		Doc. MU EV2 - Rev.03
	USE AND MAINTENANCE INSTRUCTIONS	Pagina 37 di 38











SUGGESTED SPARE PARTS LIST LPG VAPORIZERS MOD. ECOVAP FEED-OUT

DESCRIZIONE RICAMBIO/ SPARE PART DESCRIPTION	CODICE/ PART CODE
Kit per valvola controllo/Spare part kit for control valve MINI-D 1" (50-100-150-200 KG)	04100007
Kit per valvola controllo/Spare part kit for control valve MINI-DM 1" (300-500 KG)	04100037
Kit per valvola controllo/Spare part kit for control valve MINI-DM 2" NEW (750-1000 KG)	04100029
Kit per valvola controllo con visore/Spare part kit for control valve with viewer MINI-D 1" (50-100-150-200 KG)	04100020
Kit per valvola controllo con visore/Spare part kit for control valve with viewer MINI-DM 1" (300-500 KG)	04100038
Kit per valvola controllo con visore/Spare part kit for control valve with viewer MINI-DM 2" NEW (750-1000 KG)	04100034
Tappo per visore/Cap for viewer	04100032
Sonda termostatica Ø12 lato acqua e gas/Thermostatic probe Ø12 water and gas side	36080045
Tasca Ø12 per sonda termostatica/Socket Ø12 for thermostatic probe	36080047
Spia indicatore livello acqua ½" / Water level viewer ½" 50-100-150-200-300 KG	36090002
Spia indicatore livello acqua ¾" / Water level viewer ¾" 500-750 KG	36090037
Termostato di regolazione resistenza elettrica/Working thermostat for heater (70°C)	12020000
Termostato di sicurezza resistenza elettrica/Safety thermostat for heater (90°C)	12020001
O-ring 4137 per raccordo scorrevole flangia DN25/O-ring 4137 for sliding joint flange DN25	02160053
O-ring 164 per raccordo scorrevole flangia DN50/O-ring 164 for sliding joint flange DN50	02160063
O-ring NB70 per tappo 2"1/2 vaporizzatori ad acqua/O-ring NB70 for cap 2"1/2 for hot water vaporizers (50-100-200 KG)	02160080
Guarnizione per raccordo flangia 1" ANSI300/Gasket for joint flange 1" ANSI300	02160076
Guarnizione per raccordo flangia 2" ANSI300/Gasket for joint flange 2" ANSI300	02160077
O-ring 834 per resistenza elettrica 2"/O-ring for electric resistance 2" (50 KG)	02160083
O-ring 232 per resistenza elettrica 2"1/2/O-ring for electric resistance 2"1/2 (100-150-200-300 KG)	02160082
Guarnizione per resistenza elettrica 6" ANSI150/Gasket for electric resistance 6" ANSI150 (500-750 KG)	02160078
Pressacavo Eexd ½"NPT/Eexd cable gland ½"NPT (50-100-150-200-300)	37040049
Pressacavo Eexd 1"NPT/Eexd cable gland 1"NPT (50-100-150-200-300)	37040050
Pressacavo Eexd 1"½" NPT/Eexd cable gland 1"½" NPT (500-750 KG)	37040039
Tappo Eexd ½"NPT/Eexd cup ½"NPT	37040063
Tappo Eexd 1"NPT/Eexd cup 1"NPT	37040064
Tappo Eexd 1"1/2NPT/Eexd cup 1"1/2NPT	37040065

WE HIGHLY SUGGEST TO KEEP STOCK OF COMPLETE CONTROL VALVE (SEE PRICE LIST OR ASK TO OUR SALES DEPT)



MAINTENANCE TOOLS FOR THERMOSTATIC CONTROL VALVE

Pos.	DESCRIZIONE/DESCRIPTION	APPLICAZIONE/APPLICATION	IMMAGINE/IMAGE
1	CHIAVE BRUGOLA 5 MM <i>Allen Wrench size 5 mm</i>	VITI CORPO <i>Body screws</i>	
2	CHIAVE BRUGOLA 1.5 MM <i>Allen Wrench size 1.5 mm</i>	SENSORE TEMPERATURA CILINDRO VITE DI REGOLAZIONE/ <i>Temperature sensor regulation screw cylinder</i>	
3	CIACCIAVITE A TAGLIO 10 MM <i>Flathead Screwdriver 10 mm thk</i>	VITE DI REGOLAZIONE <i>Regulation screw</i>	
4	CHIAVE INGLESE 27 <i>Wrench Size 27</i>	CILINDRO DI REGOLAZIONE <i>Regulation cylinder</i>	
5	CHIAVE INGLESE 36 <i>Wrench Size 36</i>	TAPPO INFERIORE PER FILTRO TAPPO SUPERIORE ALBERO OTTURATORE <i>Bottom cap for filter Upper cap for shutter shaft</i>	
6	CHIAVE INGLESE 10 <i>Wrench size 10</i>	DADO OTTURATORE <i>Shutter screw</i>	
7	CHIAVE TUBOLARE ESAGONALE 13x13 <i>Hexagonal Tubular Wrench 13x13</i>	DADO OTTURATORE (VERSIONE CON VISORE) <i>Shutter screw (Viewer Version)</i>	
8	CALIBRO <i>Caliper</i>	MISURA TARATURA <i>Setting measurement</i>	
9	PINZA <i>Nipper</i>	ALBERO OTTURATORE <i>Shutter shaft</i>	
10	CAVA O-RING <i>O-Ring removal hook</i>	O-RING	

Bourdon tube pressure gauge Model 213.53, liquid filling, stainless steel case

WIKA data sheet PM 02.12



for further approvals
see page 2

Applications

- For measuring points with high dynamic pressure loads or vibrations
- For gaseous and liquid media that are not highly viscous or crystallising and will not attack copper alloy parts
- Hydraulics
- Compressors, shipbuilding

Special features

- Vibration and shock resistant
- Especially sturdy design
- NS 63 and 100 with German Lloyd and Gosstandart approval
- Scale ranges up to 0 ... 1,000 bar



Bourdon tube pressure gauge, model 213.53.100,
lower mount

Description

Design

EN 837-1

Nominal size in mm

50, 63, 100

Accuracy class

NS 50, 63: 1.6

NS 100: 1.0

Scale ranges

NS 50: 0 ... 1 to 0 ... 400 bar

NS 63, 100: 0 ... 0.6 to 0 ... 1,000 bar

or all other equivalent vacuum or combined pressure and vacuum ranges

Pressure limitation

NS 50, 63: Steady: 3/4 x full scale value

Fluctuating: 2/3 x full scale value

Short time: Full scale value

NS 100: Steady: Full scale value

Fluctuating: 0.9 x full scale value

Short time: 1.3 x full scale value

Permissible temperature

Ambient: -20 ... +60 °C

Medium: +60 °C maximum

Temperature effect

When the temperature of the measuring system deviates from the reference temperature (+20 °C):

Max. ± 0.4 %/10 K of the span

Ingress protection

IP 65 per EN 60529 / IEC 60529

Standard version

Process connection

Copper alloy,
lower mount (LM) or back mount (BM),
NS 50, 63: G ¼ B (male), 14 mm flats
NS 100: G ½ B (male), 22 mm flats

Pressure element

NS 50:
Copper alloy, C-type or helical type

NS 63:
≤ 400 bar: Copper alloy, C-type or helical type
> 400 bar: Stainless steel 316L, helical type

NS 100:
< 100 bar: Copper alloy, C-type
≥ 100 bar: Stainless steel 316L, helical type

Movement

Copper alloy

Dial

NS 50, 63: Plastic ABS, white, with pointer stop pin
NS 100: Aluminium, white, black lettering

Pointer

NS 50, 63: Plastic, black
NS 100: Aluminium, black

Window

Plastic, crystal-clear

Case

Natural finish stainless steel, with blow-out device with
NS 50: in case back, 12 o'clock
NS 63, 100: at case circumference, 12 o'clock
O-ring seal between case and connection.
Scale ranges ≤ 0 ... 16 bar with compensating valve to vent case.

Bezel ring

Crimp ring, glossy finish stainless steel, triangular bezel

Filling liquid

Glycerine

Options

- Other process connection
- Sealings (model 910.17, see data sheet AC 09.08)
- Measuring system and movement from stainless steel (model 233.53)
- NS 100: Zero adjustment (in front)
- Increased medium temperature with special soft solder
 - NS 50, 63: 100 °C
 - NS 100: 150 °C
- Ambient temperature resistant -40 ... +60 °C with silicone oil filling
- NS 50: Higher scale ranges up to 0 ... 1,000 bar
- Panel mounting flange, stainless steel, for back connection
- Surface mounting flange, stainless steel (not NS 50)
- Mounting clamp (for back connection)

CE conformity

Pressure equipment directive

97/23/EC, PS > 200 bar, module A, pressure accessory

Approvals

- **GL**, ships, shipbuilding (e.g. offshore), Germany
- **EAC**, import certificate, customs union Russia/Belarus/Kazakhstan
- **GOST**, metrology/measurement technology, Russia
- **KBA**, automotive, European Community
- **CRN**, safety (e.g. electr. safety, overpressure, ...), Canada

Certificates ¹⁾

- 2.2 test report per EN 10204 (e.g. state-of-the-art manufacturing, material proof, indication accuracy)
- 3.1 inspection certificate per EN 10204 (e.g. indication accuracy)

1) Option

Approvals and certificates, see website

Dimensions in mm

Standard version

Lower mount (LM)

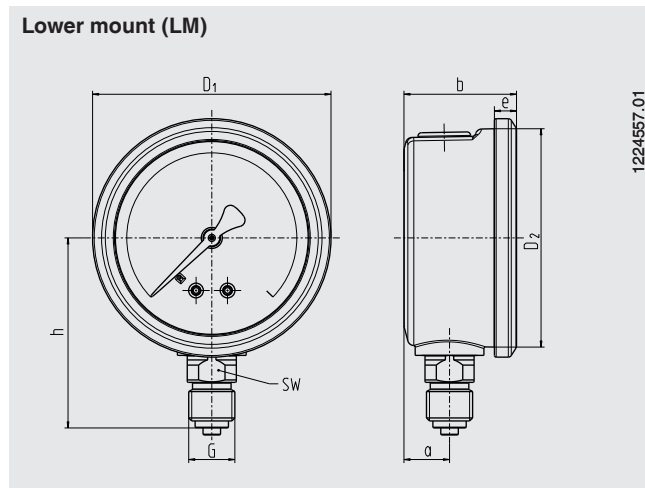

1224557.01

NS 50, 63, centre back mount (CBM)

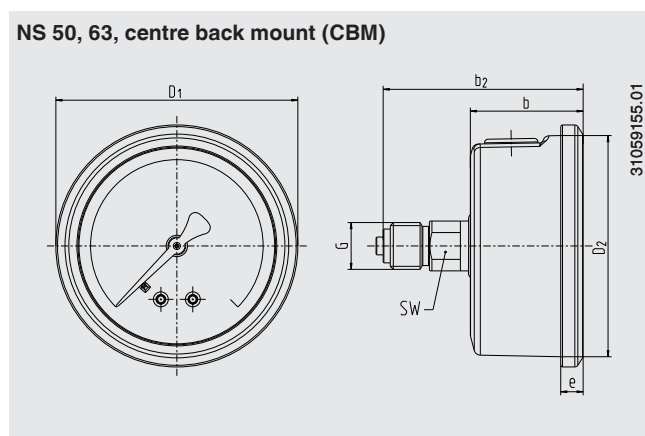

31059155.01

NS 100, lower back mount (LBM)

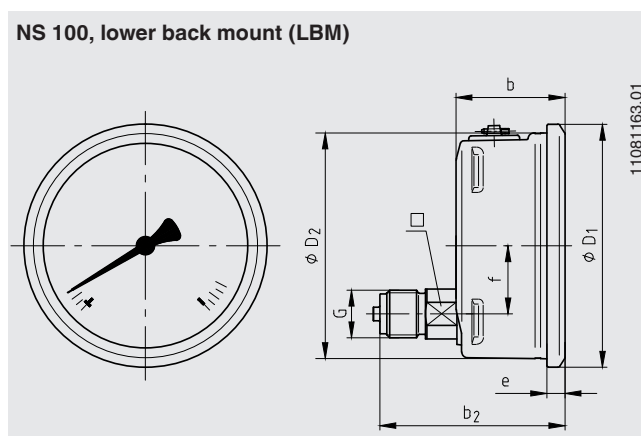

11081163.01

NS	Dimensions in mm										Weight in kg
	a	b ±0.5	b ₂ ±0.5	D ₁	D ₂	e	f	G	h ±1	SW	
50	12	30	55	55	50	5.5	-	G ¼ B	48	14	0.15
63	13	32	56	68	62	6.5	-	G ¼ B	54	14	0.21
100	15.5	48	81.5	107	100	8	30	G ½ B	87	22	0.80

Process connection per EN 837-1 / 7.3

Ordering information

Model / Nominal size / Scale range / Connection size / Connection location / Options

© 2008 WIKA Alexander Wiegand SE & Co. KG, all rights reserved.
The specifications given in this document represent the state of engineering at the time of publishing.
We reserve the right to make modifications to the specifications and materials.



Pressure gauges

Examples:

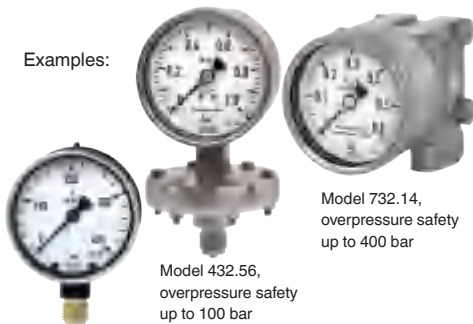

Model 213.40

Model 432.56,
overpressure safety
up to 100 bar

Model 732.14,
overpressure safety
up to 400 bar



Part of your business

Notes per current pressure equipment directive

- The pressure gauges are defined as "pressure accessories"
- The volume of the "pressure-bearing housings" of WIKA pressure gauges is < 0.1 L
- The pressure gauges carry CE marking for fluid group 1 per annex II, diagram 1 when their permissible working pressure is > 200 bar

Instruments that do not carry the mark are manufactured per article 4, paragraph 3 "sound engineering practice".

Applicable standards (depending on model)

- EN 837-1 Bourdon tube pressure gauges, dimensions, metrology, requirements and testing
- EN 837-2 Selection and installation recommendations for pressure gauges
- EN 837-3 Diaphragm and capsule pressure gauges, dimensions, metrology, requirements and testing

Specifications: See data sheet at www.wika.de

Subject to technical modifications.

© WIKA Alexander Wiegand SE & Co. KG 2009

WIKAL Alexander Wiegand SE & Co. KG

Alexander-Wiegand-Straße 30

63911 Klingenberg/Germany

Tel. +49 9372 132-0

Fax +49 9372 132-406

info@wika.de

www.wika.de

2408976.06 12/2016

1. Safety



WARNING!

Before installation, commissioning and operation, ensure that the appropriate pressure gauge has been selected in terms of measuring range, design and suitable wetted material (corrosion) for the specific measuring conditions. In order to guarantee the measurement accuracy and long-term stability specified, the corresponding load limits must be observed.

Only qualified persons authorised by the plant manager are permitted to install, maintain and service the pressure gauges.

For hazardous media such as oxygen, acetylene, flammable or toxic gases or liquids, and refrigeration plants, compressors, etc., in addition to all standard regulations, the appropriate existing codes or regulations must also be followed.

From pressure gauges which do not correspond to a safety version per EN 837 highly pressurised media might leak out through the possibly bursting window in case of a component failure. For gaseous media and working pressures > 25 bar a pressure gauge with safety version S3 is recommended per EN 837-2.

After an external fire, pressure media can leak out, particularly at soft solder joints. All instruments must be checked and, if necessary, replaced before recommissioning the plant.

Non-observance of the respective regulations can cause serious injuries and/or damage to the equipment.

2. Mechanical connection

In accordance with the general technical regulations for pressure gauges (e.g. EN 837-2). When screwing the instruments in, the force required to do this must not be applied through the case, but only through the spanner flats provided for this purpose, and using a suitable tool.

For parallel threads, use flat gaskets, lens-type sealing rings or WIKA profile sealings at the

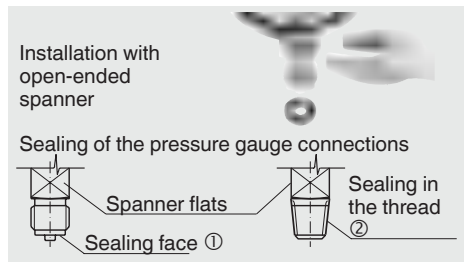

sealing face ①. With tapered threads (e.g. NPT threads), sealing is made in the threads ② using additional sealing materials, e.g. PTFE tape (EN 837-2).

The torque depends on the sealing used. In order to orientate the measuring instrument so that it can be read as well as possible, a connection with clamp socket or union nut should be used. When a blow-out device is fitted to a pressure

gauge, it must be protected against being blocked by debris and dirt. With safety pressure gauges (see ⑤) there must be a free space of > 15 mm behind the blow-out back.

After installation, open the vent valve (if available) or set from CLOSE to OPEN. With models 4 and 7, do not open the flange mounting screws. The version of the vent valve depends on the model and can deviate from the above illustration!



Requirements for the installation point

If the line to the measuring instrument is not adequately stable, a measuring instrument holder should be used for fastening (and possibly via a flexible capillary). If vibrations cannot be avoided by means of suitable installation, instruments with liquid filling should be used. The instruments should be protected against coarse dirt and wide fluctuations in ambient temperature.

Note for model 732.14, for front bezel mounting: The front bezel serves as centring and as the aperture in the mounting panel. Securing and thus the weight-bearing must be made via the pressure connection piping.

3. Permissible ambient and operating temperatures

When mounting the pressure gauge it must be ensured that, taking into consideration the influence of convection and heat radiation, no deviation above or below the permissible temperature limits can occur. Observe the influence of temperature on the indication accuracy!

4. Storage

To protect the pressure gauges from mechanical damage keep them in the original packaging until installation.

Protect the measuring instruments from humidity and dust.

Storage temperature range: $-40 \dots +70$ °C

Storage temperature range model PG23LT: $-70 \dots +70$ °C

5. Maintenance and repairs

The pressure gauges are maintenance-free. Regular checks should be carried out to ensure the measurement accuracy. Checks or recalibrations must only be carried out by qualified skilled personnel with the appropriate equipment. When dismantling, close the vent valve (if available).



WARNING! Residual media in dismantled pressure gauges can result in a risk to persons, the environment and equipment. Take sufficient precautionary measures.



Industrie Service

CERTIFICATE

The Certification Body of
TÜV SÜD Industrie Service GmbH,
a Notified Body of the Pressure Equipment Directive (PED),
certifies that



Alexander Wiegand SE & Co. KG
Alexander-Wiegand-Straße
63911 Klingenberg, Germany

implemented, operates and maintains a quality
assurance system as described in the Pressure Equipment
Directive 2014/68/EU Annex III, Module H

for the scope of

design, manufacture and sales of

- Equipment
- Pressure-containing thermowells with or without thermometer DN > 25
- Diaphragm seals
- Flange mounting components for temperature measuring points DN > 25

The audit with the report number Q-IS-TAF-MUC-PED-461882-001-19
proves that the quality assurance system fulfils the PED requirements.

The manufacturer is authorized to provide the pressure equipment
produced within the scope of the assessed quality assurance system with
the following Notified Body number:

CE 0036

Certificate No.: DGR-0036-QS-1036-20

valid until October 29th, 2023

provided that annual surveillance audits have been performed successfully

Filderstadt, November 04th, 2020

TÜV SÜD Industrie Service GmbH
Westendstraße 199
80686 München
Germany

Martin John

Notified Body No.: 0036

Tel.: +49 711 70 05 289
Fax: +49 711 70 05 582
e-mail: marina.john@tvsud.com



**GUGLIELMI
DANILO**



ISO 9001:2008
Certificato n° 1200218-09/08

Guglielmi Danilo S.r.l.

Via dell'Artigianato, 31 - 36050 Bolzano Vicentino (VI) - Italia

Tel. 0444/350025 - Fax 0444/351250

E-mail: guglielmi.danilo@artigian.vi.it - Web Site: www.guglielmidanilo.it

Reg.Imp.Vicenza, Cod.Fisc.e Part. IVA:02951940242

Cap.Soc.Euro 80.000,00 i.v.

-COSTRUZIONI APPAR. E ACCESSORI
PER IL GAS

-MANUFACTURING OF EQUIPMENT
AND DEVICES FOR GAS

-VALVOLE E FILTRI

-VALVES AND FILTERS

-LAVORAZIONI MECCANICHE

-MACHINING

CERTIFICATO DI COLLAUDO CONFORME A: UNI EN 10204 - 3.1
TESTING CERTIFICATE ACCORDING TO: UNI EN 10204 - 3.1

VALVOLA PORTA MANOMETRO A SPILLO
NEEDLE COCK VALVE

ART./ITEM CODE: **14030 - 14032**

Cliente/Customer: **PEGORARO GAS TECHNOLOGIES SRL**
Ordine/Order: **209**

Data/Date: **02/03/2022**

CARATTERISTICHE GENERALI/
MAIN SPECIFICATIONS

Conessioni/Connections: **R, Rp 1/4" - 1/2" UNI-ISO 7/1**
Press.Max.di eserc./Max working Pres.: **50 bar**

CORPO/BODY: **11SMnPb37 UNI EN 10277**
PERNO/PIN: **CW614N UNI EN 12164:98**
ANELLI OR/RING OR: **NBR**

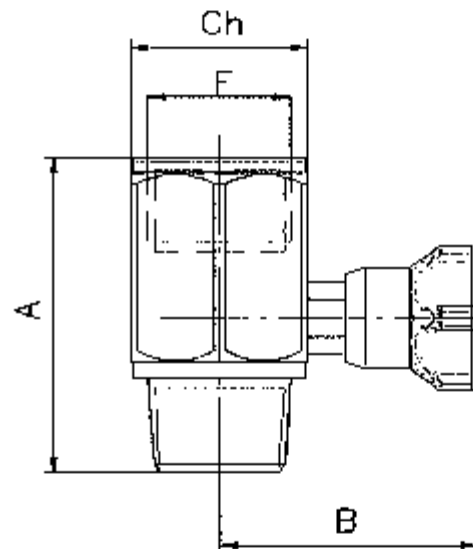

CODE	A	B	F	Ch
14030	47	37	G 1/4"	20
14032	50	40	G 1/2"	28

Prova pneumatica/Pneumatic test: **55 bar**

NOTE/NOTES:

Firma del cliente/Customer signature

Firma del costruttore/Manufacturer signature

GUGLIELMI DANILO S.R.L.
Via dell'Artigianato, 31
36050 Bolzano Vicentino (VI)
Codice Fiscale 02951940242



TERMOMETRI BIMETALLICI

BIMETALLIC THERMOMETERS



CARATTERISTICHE COSTRUTTIVE

Classe di precisione: 1,6 secondo EN 13190

Dimensione nominale: 60, 80, 100 e 150 mm

Cassa e anello: AISI 430 (DN 60-80-100)
AISI 304 (DN 150)

Gambo: in ottone nichelato, Ø 9 mm, lunghezza 50÷600 mm

Elemento di misura: spirale bimetallica

Movimento amplificatore: in ottone

Quadrante: in alluminio bianco con graduazioni in nero

Lancetta: in alluminio ossidato nero

Azzeramento: sul terminale del gambo

Trasparente: in vetro

Guarnizione: in neoprene

Grado di protezione: IP44 - IP55 (solo per DN 150)
secondo CEI EN 60529

Limite temperatura ambiente: -20...+60°C

Campo scala: vedi tabella campi scala (pag. 4)

Limite: non superare il 75% del valore di fondo scala e/o del valore estremo della scala per temperature inferiori a 0°C

Sovratemperatura: +30% A.C. per temperature ≤400°C, sovratemperatura limite 500°C

TECHNICAL CHARACTERISTICS

Accuracy class: 1,6 as per EN 13190

Nominal size: 60, 80, 100 and 150 mm

Case & Ring: AISI 430 (DN 60-80-100)
AISI 304 (DN 150)

Shank: in nickel-plated brass, Ø 9 mm, length 50÷600 mm

Temperature element: coiled bimetal

Amplifying movement: in brass

Dial: in white aluminium with black scale

Pointer: in black oxidised aluminium

Reset: at the end of shank

Dial cover: in glass

Seal: in neoprene

Protection degree: IP44 - IP55 (only for DN 150)
as per CEI EN 60529

Ambient temperature: -4...+140°F (-20...+60°C)

Scale ranges: see table scale ranges (pg. 4)

Limit: not exceed 75% of the full scale value and/or the end value of the scale for temperatures below +32°F (0°C)

Overrange: +30% F.S. for temperature ≤700°F (400°C), max 900°F (500°C)

I **termometri bimetallici posteriori** oltre al normale utilizzo negli impianti termici vengono usati in tutte quelle applicazioni industriali dove il mercurio è vietato dalla normativa in corso. Es.: impianti petroliferi, alimentari e farmaceutici.

Sono strumenti che ricevono le variazioni di temperatura sfruttando la dilatazione di una spirale bimetallica alla cui estremità è posta la lancetta indicativa. Costruzione secondo EN 13190.

Rear connection bimetallic thermometers in addition to their normal use in heating systems, are also used in all industrial applications where the use of mercury is prohibited by current regulations. E.g.: in oil refineries, food and pharmaceutical process plants.

They are instruments which detect temperature variations by measuring the expansion of a bimetallic spiral at the end of which a indicator hand is placed. Construction according to EN 13190.



CARATTERISTICHE COSTRUTTIVE

Classe di precisione: 2,5 (DN 32-40-50) secondo EN 13190
1,6 (DN 60-80-100-150) secondo EN 13190

Dimensione nominale: 32, 40, 50, 60, 80, 100 e 150 mm

Cassa e anello: ottone cromato o lega leggera (DN 32-40-50)
AISI 430 (DN 60-80-100)
AISI 304 (DN 150)

Gambo: in ottone nichelato, Ø 9 mm, lunghezza 40÷600 mm

Quadrante: in alluminio bianco con graduazioni in nero

Lancetta: in alluminio ossidato nero

Azzeramento: sul terminale del gambo

Trasparente: in vetro

Guarnizione: in neoprene

Grado di protezione: IP44 - IP55 (solo per DN 150)
secondo CEI EN 60529

Limite temperatura ambiente: -20...+60°C

Campo scala: vedi tabella campi scala (pag. 4)

Limite: non superare il 75% del valore di fondo scala e/o del valore estremo della scala per temperature inferiori a 0°C

Sovratemperatura: +30% A.C. per temperature ≤400°C, sovratemperatura limite 500°C

TECHNICAL CHARACTERISTICS

Accuracy class: 2,5 (DN 32-40-50) as per EN 13190
1,6 (DN 60-80-100-150) as per EN 13190

Nominal size: 32,40, 50, 60, 80, 100 and 150 mm

Case & Ring: chrome-plated brass or light alloy (DN 32-40-50)
AISI 430 (DN 60-80-100)
AISI 304 (DN 150)

Shank: in nickel-plated brass, Ø 9 mm, length 40÷600 mm

Dial: in white aluminium with black scale

Pointer: in black oxidised aluminium

Reset: at the end of shank

Dial cover: in glass

Seal: in neoprene

Protection degree: IP44 - IP55 (only for DN 150)
as per CEI EN 60529

Ambient temperature: -4...+140°F (-20...+60°C)

Scale ranges: see table scale ranges (pg. 4)

Limit: not exceed 75% of the full scale value and/or the end value of the scale for temperatures below +32 °F (0 °C)

Overrange: +30% F.S. for temperature ≤700°F (400°C), max 900°F (500°C)

501/F

Termometri bimetallici per fumi

Bimetallic thermometers for fumes

**504**

Termometro bimetallico con staffa per canale

Bimetallic thermometer with bracket for channel

**519**

Termometro bimetallico con flangia

Bimetallic thermometer with flanges

**505**

Termometro a bracciale con molla

Bracelet thermometer with spring

**CARATTERISTICHE COSTRUTTIVE**

Classe di precisione: 1,6 (mod 501/F-504-519) secondo EN 13190
2,5 (mod 505) secondo EN 13190

Dimensione nominale: 60 e 80 mm (mod. 501/F)
60, 80 e 100 mm (mod. 504)
65 mm (mod. 505)
80 mm (mod. 519)

Cassa e anello: AISI 430 (mod. 501/F - 504 - 519)
in ottone nichelato con anello in ferro cromato (mod. 505)

Gambo: in AISI 304, Ø 9 mm, L 100÷500 mm (mod. 501/F)
in ottone nichelato, Ø 9 mm, L 100÷600 mm (mod. 504)
in ottone nichelato, Ø 9 mm, L 50÷500 mm (mod. 519)

Elemento di misura: spirale bimetallica

Quadrante: in alluminio bianco con graduazioni in nero

Lancetta: in alluminio ossidato nero

Azzeramento: sul terminale del gambo

Trasparente: in vetro

Molla: AISI 302 (solo per mod. 505)

Grado di protezione: IP44 secondo CEI EN 60529

Limite temperatura ambiente: -20...+60°C

Campo scala: vedi tabella campi scala (pag. 4)

Limite: non superare il 75% del valore di fondo scala e/o del valore estremo della scala per temperature inferiori a 0°C

Sovratemperatura: +30% A.C. per temperature ≤400°C, sovratemperatura limite 500°C

TECHNICAL CHARACTERISTICS

Accuracy class: 1,6 (mod. 501/F-504-519) as per EN 13190
2,5 (mod. 505) as per EN 13190

Nominal size: 60 and 80 mm (mod. 501/F)
60, 80 and 100 mm (mod. 504)
65 mm (mod. 505)
80 mm (mod. 519)

Case & Ring: AISI 430 (mod. 501/F - 504 - 519)
in nickel-plated brass with ring in chrome-plated iron (mod. 505)

Shank: in AISI 304, Ø 9 mm, L 100÷500 mm (mod. 501/F)
in nickel-plated brass, Ø 9 mm, L 100÷600 mm (mod. 504)
in nickel-plated brass, Ø 9 mm, L 50÷600 mm (mod. 519)

Temperature element: coiled bimetal

Dial: in white aluminium with black scale

Pointer: in black oxidised aluminium

Reset: at the end of shank

Dial cover: in glass

Spring: AISI 302 (only for mod. 505)

Protection degree: IP44 as per CEI EN 60529

Ambient temperature: -4...+140°F (-20...+60°C)

Scale ranges: see table scale ranges (pg. 4)

Limit: not exceed 75% of the full scale value and/or the end value of the scale for temperatures below +32°F (0°C)

Overrange: +30% F.S. for temperature ≤700°F (400°C), max 900°F (500°C)

CAMPI SCALA per DN >60

SCALE RANGES for DN >60

-40° +40° C	-30° +50° C	-20° +40° C	-10° +40° C	0° +50° C	0° +200° C
		-20° +50° C	-10° +50° C	0° +60° C	0° +250° C
		-20° +60° C	-10° +110° C	0° +80° C	0° +300° C
		-20° +80° C	-10° +120° C	0° +100° C	0° +400° C
		-20° +120° C		0° +120° C	0° +500° C
				0° +160° C	

art. 500

DIMENSIONI

DIMENSIONS

DN	A	B	D	L
60	60	30	12	40÷500
80	81	36,5	12	40÷500
100	99	39	12	40÷500
150	167	50	12	40÷500

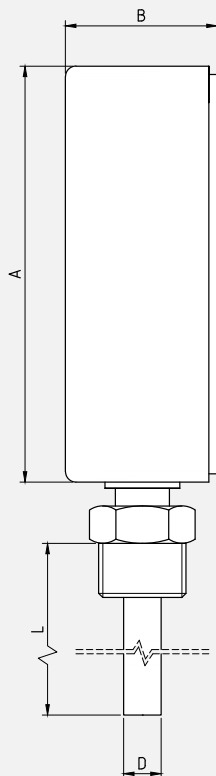

Radiale

Lower connection

OPZIONI E ACCESSORI

- scala speciale
- pozzetto termometrico ricavato da barra o da tubo, con attacco al processo filettato

art. 501

DIMENSIONI

DIMENSIONS

DN	A	B	D	L
32	32,5	10	12	50÷500
40	41	11	12	50÷500
50	50,5	11	12	50÷500
60	60	12	12	50÷500
80	80	13,5	12	50÷500
100	99	15	12	50÷500
150	167	22	12	50÷500

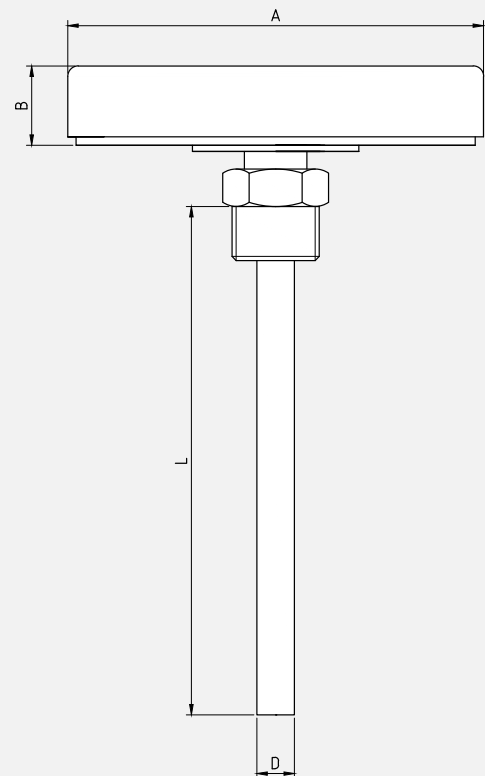

Posteriore

Back connection

OPTIONS AND ACCESSORIES

- special scale
- barstock type of from pipe thermowell with threaded or flanged process connection



I **pozzetti** conferiscono al bulbo una protezione meccanica, inoltre lo proteggono da effetti corrosivi. Permettono l'intecambiabilità dell'apparecchio garantendo la tenuta del recipiente. La conduzione termica tra bulbo e pozzetto può essere assicurata con olio minerale o polveri d'alluminio.

Pockets provide mechanical protection for the bulbs, and additionally protect them from corrosive effects. They permit the interchangeability of the instruments, ensuring the tightness of the container. Heat conduction between the bulb and the pocket can be ensured by means of mineral oil or aluminium powders.

CARATTERISTICHE COSTRUTTIVE

Ø interno: 10 mm

Ø esterno: 12 mm, a norme INAIL (ex ISPESL)

Lunghezza minima: 40 mm (compreso filetto)

Lunghezza massima: 500 mm (compreso filetto)

Si costruiscono in: ottone con saldatura stagno o argento
acciaio C40 con saldatura argento
acciaio inox AISI 316 con saldatura T.I.G.

Tipologia: ricavato da tubo

Collegamento alla sonda: attacco liscio (senza filettatura)
con grano di bloccaggio

Limite di impiego: 16 bar / 150°C (per OT58/rame)

TECHNICAL CHARACTERISTICS

Ø internal: 10 mm

Ø external: 12 mm, in compliance with INAIL standards

Minimum length: 40 mm

Maximum length: 500 mm

Manufactured in: brass with soft or silver soldering
C40 steel with silver soldering
AISI 316 stainless steel with T.I.G. soldering

Type: pocket from tube

Connection to thermometer: smooth connection (without threads)
with locking dowel

Working limit: 16 bar / 150°C (for OT58/copper)

Collegamento alla sonda con attacco liscio

Connection to thermometer with smooth connection

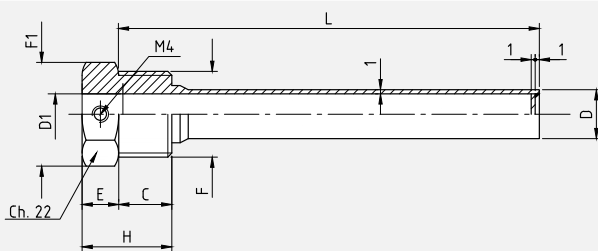

D	D1	F	F1	C	E	H	L
12	10	1/2"G	25	13	9	22	40÷500



FRATELLI MAGNI s.r.l.

info@fratellimagni.com

www.fratellimagni.com

**TERMOMETRI-MANOMETRI
PER COSTRUZIONI INDUSTRIALI**



GORGONZOLA (MI) - VIA PARINI, 60 - telefono 02.95.30.28.68-69-60



Italia

DICHIARAZIONE

[1] **AVVISO DI RICEVIMENTO**

[2] **Apparecchiature o Sistemi di Protezione destinati ad essere utilizzati in atmosfere potenzialmente esplosive
Direttiva 94/9/CE**

[3] Numero dell'Avviso di Ricevimento:

TÜV IT 15 ATEX 021 AR

[4] Apparecchiatura o Sistema di Protezione:

- **Art. 564: manometro completamente inox**
- **Art. 500/1 e 501/1: termometro bimetallico inox**

Identificazione del fascicolo tecnico
data dal richiedente:

FT001

[5] Richiedente: F.lli Magni di Magni Adelia & C. S.A.S.
Via Parini 60
I-20064 GORGONZOLA (MI)

[6] Costruttore: F.lli Magni di Magni Adelia & C. S.A.S.
Via Parini 60
I-20064 GORGONZOLA (MI)

[7] Il TÜV Italia, organismo notificato n° 0948 in conformità all'articolo 9 della Direttiva 94/9/CE del Consiglio dell'Unione Europea del 23 Marzo 1994, avvisa il richiedente di aver ricevuto il fascicolo tecnico relativo all'apparecchiatura o sistema di protezione sopra citato in accordo alla procedura definita all'articolo 8 paragrafo 1-b-I della Direttiva 94/9/CE.

Questa dichiarazione può essere riprodotta solo integralmente e senza alcuna variazione.

Data: 23 Marzo 2015

Segreteria divisione Industry Service

Veronica Inerra



ISO 9001:2015 ISO 14001:2015
SGS n° 0180 IFS n° 0011 BSI n° 0552
SOL n° 029F PAS n° 077C IAB n° 6076

Member of TÜV Group - TÜV Group Certification
by VDA 6.3
Approved by DA, UK and JRC. Member European
Agencies

Veronica Inerra



Il TÜV Italia è stato autorizzato dal governo italiano ad operare quale organismo di certificazione di apparecchi e sistemi destinati a essere utilizzati in atmosfere potenzialmente esplosive con D.M. 08/03/2007.

VALVOLE DI SICUREZZA MOD. V3-F27-F30 SAFETY VALVES mod. V3-F27-F30

 0497

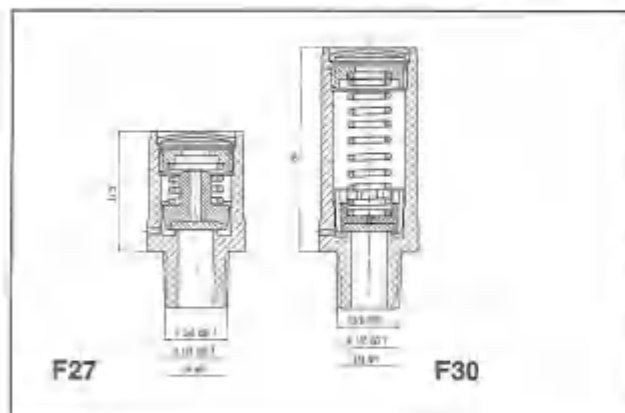
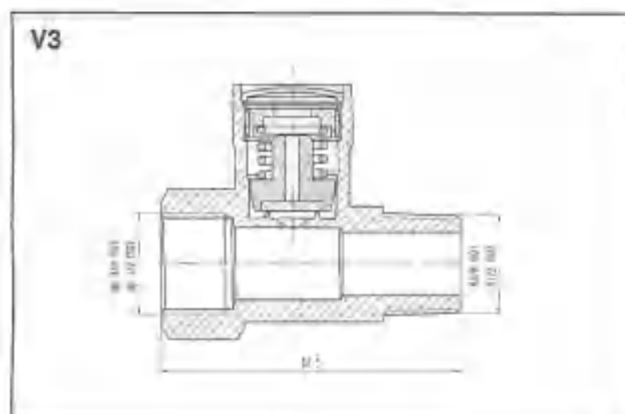

DATI DI PROGETTO

- **PRESSIONE NOMINALE**
ENTRATA - USCITA: PN 25
- **DIAMETRO NOMINALE DI SFIATO: DN 20**
- **PRESSIONE NOMINALE SFIATO: PN 10/20**
- **DIAMETRO ORIFIZIO: 9,5 mm**
- **AREA SEZIONE NETTA: 0,70 cm²**
- **ALZATA: 2,5 mm**
- **CONNESSIONI: Filettature 1/4 - 3/8 - 1/2**
tipo ISO 7 o NPT
- **PRESSIONE NOMINALE DI TARATURA:**
(vedi etichetta sul prodotto)
- **SOVRAPRESSIONE MAX: +14%**
- **SCARTO DI CHIUSURA: -15%**
- **CAMPO DI TEMPERATURA: -30 +60°C**
- **STATO FISICO DEL FLUIDO: Gassoso**
(Butano, Propano)

PROJECT DATA

- **NOMINAL PRESSURE**
INLET - OUTLET: PN 25
- **NOMINAL DISCHARGE DIAMETER: DN 20**
- **NOMINAL DISCHARGE PRESSURE: PN**
10/20
- **ORIFICE DIAMETER: 9.5 mm**
- **ORIFICE NET AREA: 0.70 cm²**
- **VALVE LIFT: 2.5 mm**
- **FITTINGS: Threads 1/4 - 3/8 - 1/2**
type ISO 7 or NPT
- **NOMINAL PRESSURE SETTING:**
(See label on product)
- **OVERPRESSURE MAX: +14%**
- **CLOSING PRESSURE: -15%**
- **TEMPERATURE RANGE: -30 +60°C**
- **PHYSICAL STATE OF FLUID: Gaseous**
(Butane, Propane)

DICHIARAZIONE DI CONFORMITA' UE

EU DECLARATION OF CONFORMITY



004302

Descrizione / Description

VALVOLA DI SICUREZZA F30 - R1/2 - 18 BAR

Marcatura / Marking



Creatore / Manufacturer

CLESSE Industries

Lotto di fabbricazione / Batch number

1255811

Quantita / Quantity

411

Data di fabbricazione / Manufacturing date

Settimana Anno / Week Year: 6 22

Norma / Standard - Regolamento / Rule

EN ISO 4126-1

Direttiva / Directive

2014/68/UE

Procedura di valutazione / Assessment procedure

Module B Production + D

Pressione massima / Nominal set pressure

18 bar

Fluido / Fluid

GPL / LPG

Categoria / Class

IV

Temperatura di utilizzo (min / max) / Operating temperature

From -30°C to +60°C

Raccordo di connessione / Connection type

R1/2

Sezione di flusso / Stream section

70 mm²

Sovrapressione / Over pressure

14 %

Pressione di richiusura / Reseat pressure

- 15 %

Flusso certificato (aria) / Guaranteed flow (air)

G-0,43

Noi dichiariamo, sotto nostra responsabilità, che il prodotto sopra indicato è conforme alle disposizioni della Direttiva europea 2014/68/UE relativa agli apparecchi a pressione.

Le prove eseguite sul prodotto hanno avuto esito positivo in accordo alle specifiche tecniche in vigore.

Prodotto da Classe Industries e venduto con il marchio NOVACOMET.

Certificati di conformità numero : PED/0497/3856/21 e PED/0497/3878/21

We hereby declare under our own responsibility, that the product detailed here were manufactured in accordance with the technical specifications of the contract complies with directive 2014/68/EU concerning pressure vessels.

All inspection operations and tests having been completed, this product comply with the relevant particular specifications, drawings, and relevant standards and regulations in force.

Manufactured by Classe Industries and sale under NOVACOMET brand.

Certificates of conformity nr : PED/0497/3856/21 and PED/0497/3878/21

Nome e numero dell'Organismo Notificato / Name and number of the notified body : CSI S.p.A. - 0497

SAVOIE Mathieu

Quality Manager

15/02/2022

004302

CLESSE INDUSTRIES

VIA ...

...

...

...

...



* Until 2" - Bis 2"



Atex CE Ex II 2 GD

* Marking Atex on request
* Atex Markierung auf Anfrage

art. 0101	F/F with aluminium lever from 1/8" to 3" F/F mit Alu-Handhebel von 1/8" bis 3"	art. 0102	M/F with aluminium lever from 1/8" to 3" M/F mit Alu-Handhebel von 1/8" bis 3"	art. 0103	M/M with aluminium lever from 1/8" to 2 1/2" M/M mit Alu-Handhebel von 1/8" bis 2 1/2"	art. 0101W	F/F without Grease from 1/4" to 2" F/F Fettfrei von 1/4" bis 2"
-----------	---	-----------	---	-----------	---	------------	--



art. 0121	F/F with aluminium T-handle from 1/8" to 1" F/F mit Alu-Flügelgriff von 1/8" bis 1"
art. 0122	M/F with aluminium T-handle from 1/8" to 1" M/F mit Alu-Flügelgriff von 1/8" bis 1"
art. 0123	M/M with aluminium T-handle from 1/8" to 1" M/M mit Alu-Flügelgriff von 1/8" bis 1"

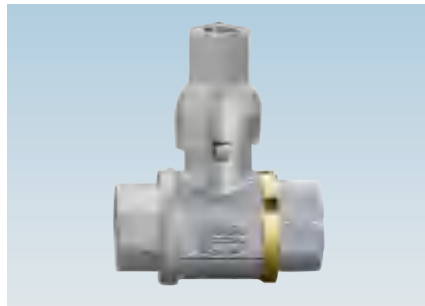

art. 0141	F/F with square cap from 3/8" to 2" F/F mit Vierkantkappe von 3/8" bis 2"
-----------	--

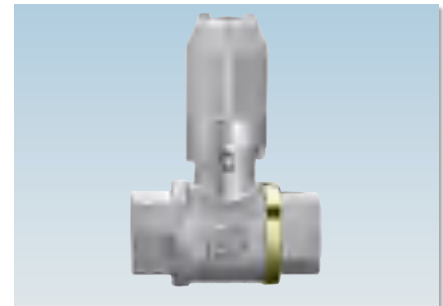

art. 0151	F/F with underground adaptor from 1/2" to 3" F/F mit Kappe für Straßenanschlüsse von 1/2" bis 3"
art. 0152	M/F with underground adaptor from 1/2" to 2 1/2" M/F mit Kappe für Straßenanschlüsse von 1/2" bis 2 1/2"
art. 0153	M/M with underground adaptor from 1/2" to 2 1/2" M/M mit Kappe für Straßenanschlüsse von 1/2" bis 2 1/2"

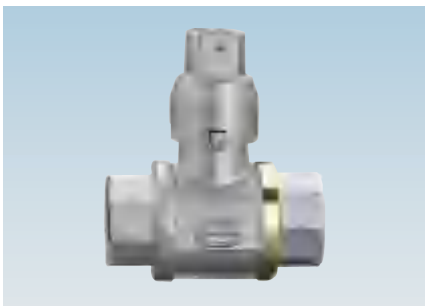

art. 0161	F/F with sealing cap from 1/2" to 3" F/F mit plombierbarer Kappe von 1/2" bis 3"
-----------	---



art. 0181	F/F with extension and lever from 3/8" to 3" F/F mit Spindelverlängerung von 3/8" bis 3"
-----------	---

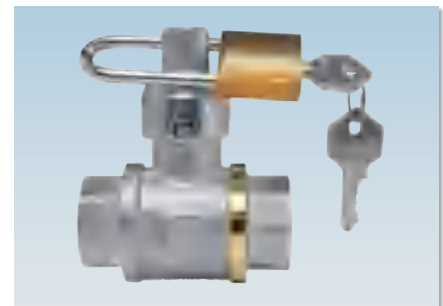

art. 0161..L	F/F lockable with padlock from 3/4" to 3" F/F verschließbar mit Vorhängeschloss von 3/4" bis 3"
--------------	--

SECTION / QUERSCHNITT

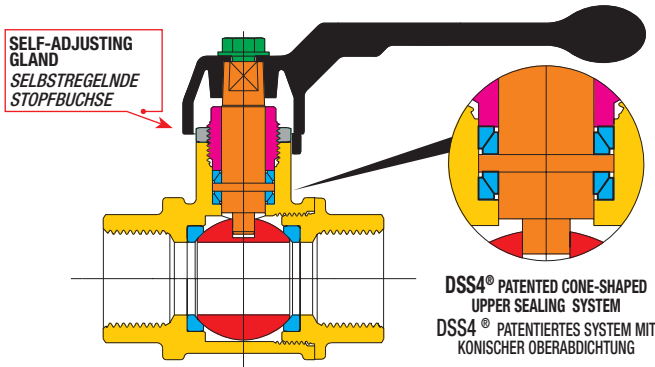

LIST OF COMPONENTS: description/materials/treatments TEILELISTE: Beschreibung / Werkstoffe / Behandlungen

Body and threaded end Gehäuse und Gewindemuffe	●	CW617N (Pb ≤ 2,2% DIN 50930T6) - UBA list
Gland Stopfbuchse	●	CW617N
Gland nut Gegenmutter	●	CW617N
Stem Betätigungsspindel	●	CW617N (Pb ≤ 2,2% DIN 50930T6) - UBA list
Chromium pl. polished ball Blank verchromte Kugel	●	CW617N (Pb ≤ 2,2% DIN 50930T6) - UBA list
Seats Dichtungen	●	PTFE
Operating device Betätigungselement	●	aluminium alloy / Alu-Legierung
Fixing screw Befestigungsschraube	●	zinc plated steel / Zinkstahl
Surface treatment Außenbehandlung	-	nickel plating outside, plain brass inside vernickelte Oberfläche, Rohe Messing innen

DIMENSIONS / ABMESSUNGEN

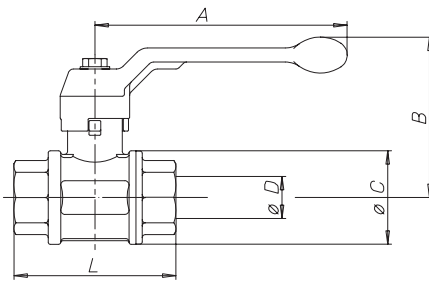

VALVE DIMENSIONS PER TYPE AND SIZE - KUGELHAHNGRÖSSE NACH TYP UND MASS

nominal diameter mm Nenndurchmesser mm	6	8	10	15	20	25	32	40	50	65	80
size in inches Zoll Abmessung	1/8"	1/4"	3/8"	1/2"	3/4"	1"	1 1/4"	1 1/2"	2"	2 1/2"	3"
Ø D bore mm Ø D durchgang mm	8	8	10	15	20	25	32	40	50	65	80
A mm	75	75	100	100	120	120	150	150	175	280	280
B mm	52	52	61	64	76	80	98	104	119	155	167
Ø C mm	23	23	29	36	45	54	65	79	96	119	144
F/F - L mm	48	51	55	69	77	89	103	114	134	160	185
M/F - L mm	49	55	60	75	86	99	113	125	147	166	195
M/M - L mm	52	55	66	82	94	108	123	136	161	172	-
Kv (for art. 0101)	5	6	8	15	28	39	84	156	243	476	770

PRESSURE/TEMPERATURE DIAGRAM - DRUCK/TEMPERATURDIAGRAMM

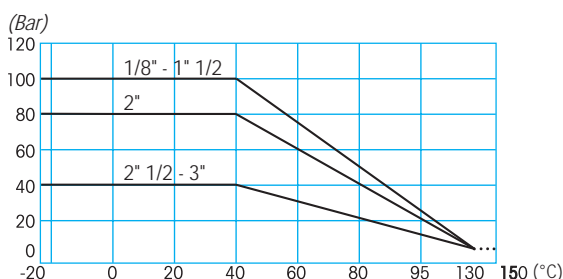

TECHNICAL FEATURES:

Temperature limits: For fluid from -20°C to +130°C with occasional peaks of 150°C for one hour.
For gas from -20 up to +60°C

Pressure limits: For fluids from 100bar to 40 bar.
For GAS MOP5

SPECIFIC FEATURES:

Bore: full.
Stem: security system with self-adjusting gland.
Seats: high resistance virgin PTFE.
Upper seal: **DSS4® Dynamic Sealing System (international patent)**
4 anti-friction self-adjusting cone-shaped seals, in PTFE and dynamic seals.
Ideal system to ensure long life cycles, high and low pressure, and vacuum (tested at 1•10⁻² mbar).
Finishing: Internal surfaces are nickel free and comply with forthcoming European drinking water regulations

Application fields:

The TOTAL series is extremely tough and is used where special performance is required, for example in the installations of gas and water distribution, industrial and civil heating, water plants at medium and high pressure, hydraulics and pneumatics, oil and petrochemical fields, non aggressive fluids, and vacuum (tested at 1•10⁻² mbar).

• On request available in **without Grease** version.

Threaded end connections:

• Standard female and male according to UNI ISO 7/1 (UNI EN 10226).
• On request NPT

Operation devices:

Aluminium lever, aluminium T-handle, square cap, underground adaptor, lockable sealing cap from 3/4".
Available colours: black, red, yellow.

All the valves comply with the regulation **CE 2014/68/CE** and are tested 100% on pneumatic seal with electronic control.

ALLGEMEINE DATEN DER STANDARDAUSFÜHRUNG:

Temperaturbereich: Für Flüssigkeiten von -20°C bis +130°C mit zufälligen Spitzen von +150°C für 1 Std.
Für GAS von -20°C bis 60°C

Betriebsdruck: Für Flüssigkeiten von 100bar bis 40bar.
Für GAS MOP5

SONSTIGE VORTEILE DER STANDARDAUSFÜHRUNG:

Durchgang: voll.
Spindel: mit Sicherheitssystem bestehend aus regelbarer Stopfbuchse.

Sitzdichtungen: reines, hochfestes PTFE.
Obere Abdichtung: **DSS4® Dynamic Sealing System (internationales Patent)**
4 konische, reibungsverhindernde PTFE gegen PTFE Dichtungen mit automatischer Regelung und dynamischer Dichtung. Ideales System für Anwendungen mit hoher Lastspielzeit, bei Hoch- und Niederdruck sowie Vakuum (1•10⁻² mbar geprüft).

Feinbearbeitung: Innen gemäß den zukünftigen europäischen Trinkwasservorschriften nicht vernickelt

Anwendungsbereich:

Die Baureihe TOTAL wird in jenen Anlagen eingesetzt, in denen Sondereinsatzbedingungen herrschen. Hierzu gehören Gas- bzw. Wasserversorgungsanlagen, Zivil- bzw. Industrieheizanlagen, hydraulische Anlagen bei mittlerem und hohem Druck, öhydraulische und pneumatische Anlagen, Chemie- und Petrochemieanlagen, für Vakuum sowie für alle nicht ätzenden Medien.

• auch **Fettfrei** erhältlich.

Gewindeanschlüsse:

• Innen- und Außengewinde nach UNI ISO 7/1 (UNI EN 10226).
• Auf Anfrage NPT

Betätigungselemente:

Alu-Handhebel, Alu-Flügelgriff, Vierkantkappe, Kappe für Straßenanschluss, plombierbare Kappe, mit Vorhängeschloss verschließbare Kappe zu 3/4".
Erhältliche Farben: schwarz, rot, gelb.

Alle Kugelhähne berücksichtigen die EG-Richtlinie 2014/68/EG und werden 100% mit einem Verfahren kontrolliert, das eine elektronisch gesteuerte Luftdichtheitsprüfung vorsieht.

MINICAL – VALCAL Automatic air vent valves

series 5020 - 5021 - 5022



cert. n° 0003
ISO 9001

01054/05 GB

Replaces 01054/99 GB



Function

Automatic air vent valves are designed to remove the air that accumulates in heating and air conditioning systems without the need for manual intervention. This prevents harmful phenomena that may compromise the life and the performance of the heating system and which include:

- corrosion due to the oxygen;
- pockets of air trapped in the heating emitters;
- cavitation in the circulation pumps.



Product range

Series 5020 MINICAL Automatic air vent valve	Sizes 3/8" and 1/2" M
Series 5020 MINICAL Automatic air vent valve, chrome plated	Sizes 3/8" and 1/2" M
Series 5020 MINICAL Automatic air vent valve, with safety hygroscopic cap	Sizes 3/4" and 1" M
Series 5020 MINICAL Automatic air vent valve, with safety hygroscopic cap, chrome plated	Sizes 3/4" and 1" M
Series 5021 MINICAL Automatic air vent valve, complete with automatic shut-off cock	Sizes 3/8" and 1/2" M
Series 5021 MINICAL Automatic air vent valve, complete with automatic shut-off cock, chrome plated	Sizes 3/8" and 1/2" M
Series 5022 VALCAL Automatic air vent valve, chrome plated	Sizes 1/4", 3/8, 1/2" M

Technical specification

Materials:

Body and cover:	brass EN 12165 CW617N
Float:	PP
Obturator stem:	brass EN 12164 CW614N
Spring:	stainless steel
Seals:	EPDM
Shut-off cock seal:	PTFE

Performance:

Medium:	water and glycol solution
Max. percentage of glycol:	30%
Max. working pressure:	10 bar
Max. discharge pressure:	5020, 5021: 2,5 bar 5022: 4 bar.
Max. working temperature:	5020, 5022: 120°C 5021: 110°C

Dimensions

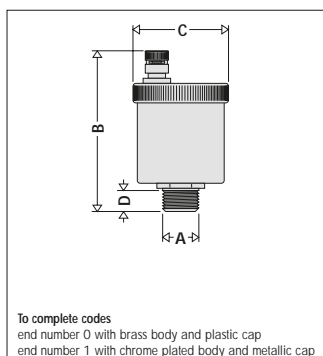

Code	A	B	C	D	Weight (kg)
50203.	3/8"	79	Ø 48	11	0,18
50204.	1/2"	79	Ø 48	11	0,18

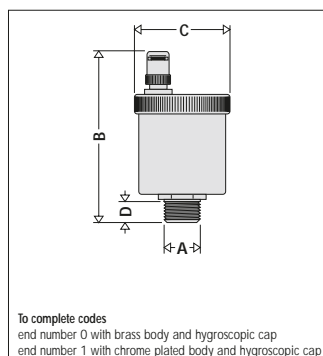

Code	A	B	C	D	Weight (kg)
50205.	3/4"	86	Ø 48	11	0,18
50206.	1"	86	Ø 48	11	0,18

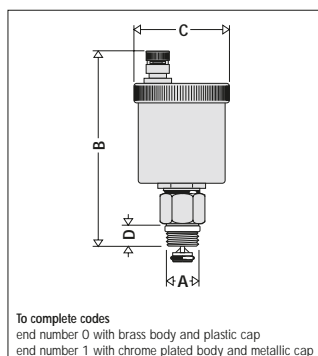

Code	A	B	C	D	Weight (kg)
50213.	3/8"	96	Ø 48	11	0,21
50214.	1/2"	96	Ø 48	11	0,23

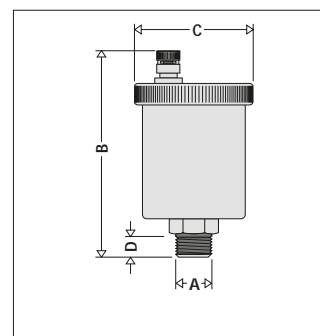

Code	A	B	C	D	Weight (kg)
50221	1/4"	94	Ø 55	9	0,29
502231	3/8"	97	Ø 55	11	0,29
502241	1/2"	97	Ø 55	11	0,29

Operation

The accumulation of air bubbles in the valve body causes the float to drop so that the air vent valve opens. This phenomenon occurs, and consequently the valve functions correctly, as long as the water pressure remains below the maximum discharge pressure.

Construction details

Hygroscopic cap

All MINICAL and VALCAL models are equipped with a hygroscopic safety cap. Its functionality is based on the properties of the cellulose fibre discs that serve as the seal cartridge and whose volume increases by 50% as soon as they become wet and thus cause the valve to close. This way, possible damages are avoided in case of leakage.

Models with shut-off

The automatic shut-off valve, which forms a seal with the valve body by means of an O-ring made of EPDM, facilitates maintenance operations by shutting off the water flow when the valve is removed and also allows for easy inspection of the air vent device.

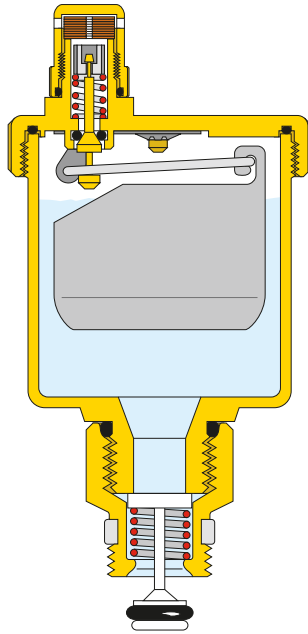

Flow curves

Air flow (when the system is being filled)

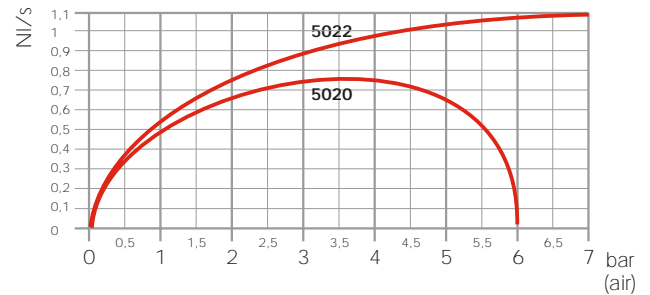

Installation

- The valve is installed in the vertical position, on the air separator, on manifolds, on riser pipes and generally in parts of the system where a concentration of air pockets is to be expected.
- During operation the upper cap in the standard version must be loosened whilst it must be completely hand tightened in the hygroscopic version.
- It is not advisable to fit the valve in places which could be subject to freeze. In such cases the Caleffi Maxcal Series 501 automatic deaerator can be used.
- It is advisable to **replace the valve cap with a Caleffi Series 5620 safety hygroscopic cap in all fitting locations which cannot be inspected.**

Accessories

- Check valve series 561 for air vent valves series 5020 and 5022 is available. 3/8" and 1/2" connections. Available in brass or chrome plated version. PTFE sealing on thread.
- Hygroscopic safety plug AQUASTOP series 5620 for MINICAL and VALCAL series is available in brass or chrome plated.
- Small anti-suction valve series 5621 for air vent valves for MINICAL and VALCAL series.



SPECIFICATION SUMMARIES

Series 5020

Automatic air vent valve. 3/8" M (or 1/2" M) threaded connection. Brass and chrome plated versions. Brass body and cover, PP float, brass obturator stem, EPDM O-Rings. Medium: water and glycol solutions. Maximum percentage of glycol 30%. Maximum working pressure 10 bar, maximum discharge pressure 2,5 bar. Maximum working temperature 120°C.

Series 5020

Automatic air vent valve. 1/2" M (or 3/4" M) threaded connection. Brass and chrome plated versions. Brass body and cover, PP float, brass obturator stem, EPDM O-Rings. Medium: water and glycol solutions. Maximum percentage of glycol 30%. Maximum working pressure 10 bar, maximum discharge pressure 2,5 bar. Maximum working temperature 120°C. Complete with hygroscopic safety cap.

Series 5021

Automatic air vent valve with automatic shut-off cock. 3/8" M (or 1/2" M) threaded connection. Brass and chrome plated versions. Brass body and cover, PP float, brass obturator stem, EPDM O-Rings. Medium: water and glycol solutions. Maximum percentage of glycol 30%. Maximum working pressure 10 bar, maximum discharge pressure 2,5 bar. Maximum working temperature 110°C.

Series 5022

Automatic air vent valve. 1/4" M (3/8", 1/2" M) threaded connection. Chrome plated with metallic cap. Brass body and cover, PP float, brass obturator stem, EPDM O-Rings. Medium: water and glycol solutions. Maximum percentage of glycol 30%. Maximum working pressure 10 bar, maximum discharge pressure 4 bar. Maximum working temperature 120°C.

We reserve the right to change our products and their relevant technical data, contained in this publication, at any time and without prior notice.



MASTERWATT

Riscaldatori Elettrici

CE

PLUG-MOUNTED ARMORED HEATERS SUITABLE FOR USE IN EXPLOSIVE AREAS

Type GTF 90/162

INSTRUCTIONS FOR ASSEMBLING, ELECTRICAL CONNECTION, START UP AND MAINTENANCE

Document n°: MAX-EX-0001 Rev. 02

Date: 27.07.2020

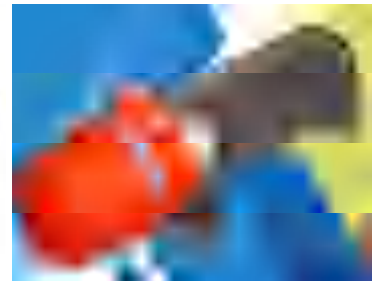

USE

The Plug-Mounted Armoured Heaters for explosive areas (Type 78/162) are electrical resistance heaters designed to tailor the customer's specific needs. Limitations to their use (which are additional to those already specified in the customer order) are detailed by Masterwatt upon delivery. As a general rule, these heaters are designed to be exclusively employed in the direct heating of solids, non flammable fluids or of flammable fluids which operate within plants with no presence of air or of oxygen. They can also be used for in-room ambient air heating.

The heaters Type 78/162 shall be exclusively employed under the operational characteristics which have been specified to Masterwatt at the moment of the order and which are recalled, for the ATEX certified heaters, in the Declaration of Conformity. The technical characteristics of these heaters (total power, specific power, supply voltage, dimensions, protection degree, explosion-proof category, protection mode) satisfy these characteristics.

With the implementation of the nameplate identifying the product, Masterwatt guarantees that the electrical construction has been designed and manufactured in accordance with the prescriptions of the product-related Ex certificate. The user shall follow the prescriptions for a correct use detailed in this manual as well as those imposed by good technique and by the applicable plant specifications with regard to the heated solid or fluid. In particular, the user shall insure that the heater specific power and its resulting maximum surface temperature, are compatible with the thermal characteristics (e.g. stability) of the heated fluids and that the maximum temperature reached by the heated solid is compatible with the mechanical properties expected from that solid. In addition, the user shall make sure to fulfil all the Special Conditions for a Safe Use that are detailed at the end of this manual.

The IP degree of protection of the electrical connection box, is insured to the extent requested by Masterwatt Customer. Should the user add parts or components or modify in any way the supplied heater, this shall be done in accordance with the same protection standard as the one granted by the Masterwatt construction. **The heaters cannot be used if modified or altered without following the requirements of the protection standard pertaining to its construction.**

If the heater is used in a potentially explosive atmosphere, the user shall insure that the operating and environmental conditions which characterize the heater operation are compatible with the protection mode granted by the heater which, towards the external environment, is Ex d – gas group IIC and/or Ex t – dusts group IIIC, while at the process side (if it constitutes a classified area) is Ex e – gas group IIC. In addition, the user shall verify that the operating temperature of the plant in which the heater operates is compatible with the temperature class the heater belongs to and that is specified on the heater label.

Explosion-Proof Heaters cannot be used in environments whose operational conditions are not consistent with the mode of protection granted by Masterwatt at delivery.

NOTE:

Due to their intrinsic characteristics, the heaters tend to absorb ambient humidity. This may lead to a reduction of the electrical insulation insured by Masterwatt at the moment of the delivery to its Customer.

ASSEMBLING

It is recommended to install the heater following the procedures detailed in EN 60079-14 (ATEX certified heaters) or IEC 60079-14 (IECEx certified heaters) specifications.

The heater is best operated in horizontal position. In case of heating of liquids, it must be insured that the heater operates only if the liquid level is at least 50 mm above the highest heating section of the heater itself as specified by Masterwatt in the documentation provided upon delivery.

For the Anticondensation Heaters the optimal installation is on the pavement, in horizontal position.



Riscaldatori Elettrici



**PLUG-MOUNTED ARMORED HEATERS
SUITABLE FOR USE IN EXPLOSIVE AREAS**

Type GTF 90/162

**INSTRUCTIONS FOR ASSEMBLING,
ELECTRICAL CONNECTION,
START UP AND MAINTENANCE**

Document n°: MAX-EX-0001 Rev. 02

Date: 27.07.2020

The heater shall be mounted in tanks or shells which grant the build up of a sufficient natural convection flow, thus preventing the creation of hot spots with too high temperatures (as an example, the heater shall not be mounted in tubes or narrow areas unless it has been explicitly designed for this type of application).

The heater shall never be activated if fluid is not present. In case the heater has been designed to operate in forced convection, the user shall insure that the fluid flow rate is never below the design value or the minimum flow rate specified by Masterwatt in the documentation provided upon delivery and that the direction of the flow is the one indicated in such documentation.

If heating fluids, the user shall foresee a proper seal at the mounting location of the heater. This seal shall be selected on the basis of the design pressure and temperature and of the physical and chemical characteristics of the heated fluid. The user shall visually check the surface of the heating elements to verify that it is clean and exempt from local deposits of material or particles which may alter the heat exchange efficiency. Once these verifications are concluded it is possible to proceed with the plant start-up.

In the heating of solids, the heater must be mechanically connected to the solid to be heated. The connection shall be sufficiently efficient to insure that the heat exchange via conduction is adequate to the process needs.

The heater is provided with a terminal box whose orientation can be adjusted by unscrewing it for a maximum of one turn (360°) to make the connection of the power supply cables and/or of the safety/control sensor cables easier.

To rotate the contact box in accordance with the installation needs, it is required to untighten the screw that blocks the anti-unscrewing bracket. After that, the contact box can be rotated in the unscrew direction (maximum 360°) to reach the desired position. Once the positioning is completed, the anti-unscrewing bracket shall be blocked again to lock the contact box in its new position.

ELECTRICAL CONNECTION

The user shall verify that the supply voltage corresponds to the value specified on the heater label and that the safety devices dedicated to the protection of the heater itself are operational. The alarm threshold shall be set by the user taking into account all the applicable regulations relevant to plants as well as the restrictions detailed by Masterwatt in the documentation provided upon delivery.

Before starting the plant, the user shall verify the correct operation of the safety chain (sensor, connection cables and safety actuators). In addition, if the process side area is classified as Zone 1 and the heater is used in a country where the ATEX Directive 2014/34/UE applies, the safety device for the control of the heating elements maximum temperature shall be part of a SIL 1 certified safety chain in accordance with the requirements of standard EN 50495. Under this respect, the device provided by Masterwatt has characteristics that are consistent with the requirements applicable to this type of certification.

If the process side area is classified as Zone 1, the user shall make sure that the heater control system is capable to identify the open circuit failure of even a single heating element in order to avoid that such failure makes the safety device ineffective (which would be the case if the failed element is exactly the one to which the safety device is clamped). If this capability is not available, the user shall request to equip the heater with two independent safety devices.

Before connecting the terminals, the user shall remove the Silica Gel pack located within the connection box (if provided) and shall make sure that the internal and external ground connection terminals are connected and tightened to the points made available by the manufacturer, using a cable compliant to the requirements of EN 60079-0 specification, par. 15.3, 15.4 and 15.5 (ATEX certified heaters) or IEC 60079-0 specification, par. 15.3, 15.4 and 15.5 (IECEx certified heaters).

The electrical connection of the terminals (R-S-T or L-N) shall be done making sure (with a proper Ohm-meter) that the electrical insulation between each phase and the ground is ≥ 2 MOhm at 500 VDC (see also section dedicated to plant start-up). Upstream the power supply circuit, a properly sized earth leakage relays shall be installed at user's care. In addition, if the process side is classified as Zone 1 or Zone 2, the earth leakage relays shall comply with the requirements of paragraph 5.8.6 of EN 60079-7 specification (ATEX certified heaters) or IEC 60079-7 specification (IECEx certified heaters).

The user shall verify that the cross section, the material and the electrical insulation of the power supply harness is compatible with the current and the cable design temperature that are specified by Masterwatt in the documentation provided upon heater delivery. In particular, the current density through the conductors shall never exceed 2 A/mm².

The user shall design the power supply cable connection device to fit directly the electrical connection box, without any interposition, making use of a coupling nipple or of a cable gland that are certified in accordance with EN 60079-0, EN 60079-1 and EN 60079-31 specifications (ATEX certified heaters) or IEC 60079-0, IEC 60079-1 and IEC 60079-31 specifications (IECEx certified heaters). The coupling threads shall be exclusively those specified in the documentation supplied upon delivery.

MASTERWATT

Riscaldatori Elettrici

CE

PLUG-MOUNTED ARMORED HEATERS SUITABLE FOR USE IN EXPLOSIVE AREAS

Type GTF 90/162

INSTRUCTIONS FOR ASSEMBLING, ELECTRICAL CONNECTION, START UP AND MAINTENANCE

Document n°: MAX-EX-0001 Rev. 02

Date: 27.07.2020

Being the electrical connection terminals of screw type, the user shall provide the supply cable with an eyelet. The connection shall be executed using two wrenches, one operating on the nut and the other blocking the lock nut: this will prevent a break of the insulation device placed on any heating element.

The user shall take care to branch the earth connectors to the bolts made available by Masterwatt inside and outside the heater terminal box (see pictures below).

Internal Earthing Terminal



External Earthing Terminal



The heater maximum start-up current in cold conditions is the one specified in the heater label. This value could be higher up to 5% more due to fabrication tolerances. A further increase is possible if the power supply voltage, in its physiological fluctuations, turns out to be temporarily above its nominal value. In these cases the increase of the start-up current in cold conditions is directly proportional to the power supply voltage increase.

The heater is designed to withstand a variation of the nominal supply voltage of $\pm 10\%$ taken for granted that the average value of the power supply voltage is equal to the nominal voltage.

The safety thermostats are set before delivery by Masterwatt. The set point has been defined to insure a safe operation of the heater and cannot be modified by the user if not to lower these values. Masterwatt declines any responsibility in case of damages to persons or goods which is caused by a modification of the thermostat set point which has not been performed by Masterwatt itself or which turns out to be an increase of the alarm temperature set by Masterwatt at delivery.

If the heater is provided with a thermocouple or a thermo-resistance, the user shall provide the thermal regulation system which is required to operate them. In this case, the alarm threshold to be set inside the control system shall be the one specified by Masterwatt in the documentation provided upon delivery. The intervention of the thermal safety device shall be followed by a transition of the plant to a safe state. In addition, the re-start of the safety device shall not be automatic.

The user shall adopt appropriate measures (restrictions of the accesses, segregation, protection passwords) to prevent that not authorized or not competent personnel may modify the setting of the safety devices.

PLANT START-UP

Before starting up the plant, all the thermal and safety characteristics shall be verified by an expert or by the manufacturer.

In addition, in case of gas heating, the user shall adopt proper purging procedures which make use of inert gases and insure that no explosive atmosphere is present inside the plant at start-up.

If the electrical insulation value, measured as described in the section "Electrical Connection", is below 2 MOhm it is still possible to proceed with the plant start up but the following procedure shall be followed:

1. Start the plant insuring a forced convection of the process fluid at a speed not below 1 m/s all around the armored heating elements and provide power supply to the heater at a voltage not exceeding 50 % of the nominal value
2. If an adequate forced convection of the process fluid cannot be insured, the procedure can be applied in "dry" conditions (i.e. in static air, without the process fluid) but in this case the power supply voltage to the heater shall not exceed 25 % of the nominal value.
3. Keep working for at least 12+24 hours
4. Stop the heater, wait for cool-down and check again the electrical insulation.
5. in case the electrical insulation is still below 2 MOhm repeat the procedure from point 1).

STORAGE

The plug-mounted heaters shall be stored in areas which are suitable for the storage of electrical products and shall be protected from humidity. The sealing caps located on the couplings (where the cable glands will be installed) prevent the entrance of humidity and shall be removed only when performing the electrical connection of the heater.

The storage temperature must not drop below $-10\text{ }^{\circ}\text{C}$.

Storage time must not exceed 6 months. If the heater must remain inactive for over 6 months, it is advisable to check the level of electrical insulation every 6 months and to restore it to the nominal values ($> 2\text{ MOhm}$) by means of the procedure described in the paragraph "Plant start-up" or returning the heater to Masterwatt for reconditioning.



Riscaldatori Elettrici



**PLUG-MOUNTED ARMORED HEATERS
SUITABLE FOR USE IN EXPLOSIVE AREAS**

Type GTF 90/162

**INSTRUCTIONS FOR ASSEMBLING,
ELECTRICAL CONNECTION,
START UP AND MAINTENANCE**

Document n°: MAX-EX-0001 Rev. 02

Date: 27.07.2020

If storage time exceeds 30 days, it is necessary to carry out a thorough examination before starting the unit.

MAINTENANCE

The required periodic maintenance operations are detailed hereafter. These operations need to be performed at least once a year unless the working conditions (or the specific instructions provided in the section below) require a higher frequency.

It is recommended to perform heater maintenance following the procedures detailed in EN 60079-17 specification (ATEX certified heaters) or IEC 60079-17 specification (IECEx certified heaters).

Attention! Before opening the terminal box it is necessary to make sure that it has cooled down (see also pictogram  on the terminal box cover).

Electrical Resistance Control

Remove power supply and disconnect power supply harness. Measure Electrical resistance at room temperature with a Ohm-meter of appropriate characteristics, making sure that it has been properly calibrated. The measurement shall be performed between Line and Neutral in case of monophasic power supply while it must be performed between phase and phase if the power supply is three-phase. The measured values shall be coherent with those reported on the wiring diagrams and/or on the acceptance testing certificates provided by Masterwatt together with the product.

Connections Control

Verify the tightness of all electrical connectors, electrical bridges and screws at least once every 6 months. If the contact box is subject to cyclic oscillations of the temperature, this verification shall be performed at least every 3 months. In addition it shall be verified that power supply cables and their insulation are in perfect conditions, exchanging them in case of questionable adequacy.

Thermal Safety Sensors verification

Verify the thermal safety sensors disconnecting the sensor cables from its thermoregulator and/or the thermostat connections from the power relays, and verifying the electrical continuity with a tester. Should the temperature sensors require substitution, this shall be done granting that the installation of the new sensors is identical to the one arranged by Masterwatt at the moment of delivery.

Heating Elements shell verification

Perform a periodic visual inspection of the heating elements shell and remove timely potential deposits accumulated during the normal operation of the plant. The removal shall be executed making use of not-abrasive devices.

Check also the tightening of the metal clamps (if any) that fix the thermowells of the safety devices to the heating elements, taking care to retighten them if necessary.

Silica Gel Pack Replacement

In case of long storage periods or of storage in a humid environment, the Silica Gel pack colour shall be verified. The pack shall be replaced if the Silica Gel pack colour is pink.

Internal cartridge replacement in Monotube heaters having internal interchangeable element

If the heater is a monotube provided with a n internal interchangeable element, it is possible to replace the cartridge which constitutes the heating element. To proceed in this operation the procedure detailed below shall be followed:

- Remove power supply to the heater
- Unscrew the contact box cover and remove all the electrical connections inside
- unscrew the cartridge to be exchanged using a socket wrench size 58 (cartridges Ø45) or size 52 (cartridges Ø57)
- Extract the cartridge to be replaced and insert the new one (see photo 1 and 2)
- Clean with compressed air both the female thread that will host the new cartridge (photo 3) and the male thread of the new cartridge itself (photo 4)
- Cover with Teflon tape the thread of the new cartridge (photo 5)
- Tighten the cartridge using the same socket wrench that was used to extract the cartridge that had to be replaced
- Blow nitrogen inside the cartridge to make sure that the gas volume inside the tube which hosts the cartridge to be replaced does not contain oxygen. To obtain this result it is required to proceed as follows:
 - Unscrew the 1/8"Gas nipple and the M4 screw located on the head of the cartridge (photo 6)
 - Connect to a nitrogen bottle the filling device that is provided with the heater as maintenance tool (photo 7)
 - Insert the filling device into the 1/8"Gas female nipple (photo 8 and 9) and blow nitrogen at a flow rate of at least 5 lt/min (photo 10) for at least 3 minutes per meter of length of the tube (e.g.: for a tube whose length is 2.5 m the blowing time shall be about 7 minutes and half) letting the air that is inside the cartridge go out from the M4 hole (photo 11)
 - Keep close at hand the screws that close the 1/8"Gas and M4 holes together with the corresponding mounting tools (photo 12). Then stop the nitrogen flow and screw quickly the M4 screw closing in this way the exit hole of the gas coming from inside the tube (photo 13)

MASTERWATT

Riscaldatori Elettrici

**PLUG-MOUNTED ARMORED HEATERS
SUITABLE FOR USE IN EXPLOSIVE AREAS**

Type GTF 90/162

**INSTRUCTIONS FOR ASSEMBLING,
ELECTRICAL CONNECTION,
START UP AND MAINTENANCE**

CE

Document n°: MAX-EX-0001 Rev. 02

Date: 27.07.2020

- Disconnect the nitrogen bottle and close quickly the bottle connection point using the 1/8" Gas nipple (photo 14 and 15)
- Re-install the electrical connections





Riscaldatori Elettrici



**PLUG-MOUNTED ARMORED HEATERS
SUITABLE FOR USE IN EXPLOSIVE AREAS**

Type GTF 90/162

**INSTRUCTIONS FOR ASSEMBLING,
ELECTRICAL CONNECTION,
START UP AND MAINTENANCE**

Document n°: MAX-EX-0001 Rev. 02

Date: 27.07.2020

SPECIAL CONDITIONS FOR A SAFE USE

- The maximum plant operational temperature, the maximum ambient working temperature and the power supply voltage shall be coherent with the values stamped on the heater label
- The power supply cable shall be suitable for an operating temperature that is equal or higher than the temperature stamped on the heater label and shall be characterised by a current density that does not exceed 2 A/mm²
- The user shall adopt adequate measures (e.g. making use of a liquid level measurement device) to insure that the heater operates only if the liquid level is at least 50 mm above the highest heating section of the heater itself as specified by Masterwatt in the documentation provided upon delivery
- the replacement of the internal heating cartridge in the heaters with hollow tubes and internal interchangeable elements shall be performed making sure that the air volume inside the tubes does not contain explosive material (gases, liquids or dusts) and following strictly the prescriptions detailed in the MAINTENANCE paragraph
- The user shall take care to clean periodically the heater terminal box with a clean cloth to prevent the accumulation of a dust layer exceeding a thickness of 5 mm
- Explosion-proof joints cannot be repaired
- Attention! Before opening the terminal box make sure that it has cooled down (see pictogram ).
- If the process side is classified as Zone 1 or Zone 2, a properly sized earth leakage relays shall be installed at user's care upstream the power supply circuit (see also paragraph 5.8.6 of EN 60079-7 specification, ATEX certified heaters, or IEC 60079-7 specification, IECEx certified heaters)
- If the process side is classified as Zone 1 or Zone 2 and it consists of static gases, the user shall make sure that the ambient temperature at which the heaters operate does never exceed the value stamped on the nameplate
- If the process side is classified as Zone 1 the user shall:
 - Remove the power supply to the heater if the flow rate drops below the minimum value specified by Masterwatt in the documentation provided upon delivery
 - Design the control system so that no failure (here including the open circuit failure of a single heating element) causes to the loss of the safety function
 - Make sure, for ATEX certified heaters, that the safety chain dedicated to the control of the maximum temperature of the heating elements is certified SIL1 in compliance with the requirements of EN 50495 Specification
- In order to prevent operational conditions that are dangerous or that are outside the nameplates limitations, each heater is provided with one or more safety devices. These devices shall be connected to the control system (see requirements in paragraph "Electrical Connection") and shall be operated so as to turn out to be additional to those dedicated to the heater nominal operation and provided with a non-automatic reset. The minimum foreseen devices are the following:
 - *Heating of solids:*
The heaters are provided with a safety device that limits the maximum plant operational temperature (solid surface temperature exposed to the explosive atmosphere).
 - *Heating of liquids and of gases in not classified processes:*
The heaters are provided with a safety device that limits the maximum plant operational temperature (internal heater coupling surface, process side).
 - *Heating of static gases in processes that are classified as Zone 1 or Zone 2:*
The heaters are designed to be self-limiting and do not need to be equipped with safety devices
 - *Heating of gases in forced convection in processes that are classified as Zone 1 or Zone 2:*
The heaters are provided with a safety device which controls the maximum temperature of the heating elements and, if required by the operational conditions, also by a safety device a that limits the maximum plant operational temperature (internal heater coupling surface, process side).
- The compliance of the heater and of the overall plant to the applicable plant specifications and to the prescriptions of this manual shall be verified by the plant manufacturer or by properly skilled personnel.

NOTE

SHOULD THE INFORMATION REPORTED IN THIS MANUAL PROVE NOT TO BE EXHAUSTIVE, THIS SHALL BE NOTIFIED TO MASTERWATT.



Riscaldatori Elettrici

**PLUG-MOUNTED ARMORED HEATERS
SUITABLE FOR USE IN EXPLOSIVE AREAS**

Type GTF 90/162

**INSTRUCTIONS FOR ASSEMBLING,
ELECTRICAL CONNECTION,
START UP AND MAINTENANCE**



Document n°: MAX-EX-0001 Rev. 02

Date: 27.07.2020

DESCRIPTION

The Plug-Mounted Armoured Heaters for explosive areas type GTF 78/162 are designed and manufactured in accordance with ATEX Directive 2014/34/UE. They belong to group II, they are category 2 electrical apparatuses and they are suitable to operate in areas with risks of explosion due to the presence of explosive gases ("G") or powders ("D"). They comply to specifications EN 60079-0, EN 60079-1, EN 60079-7 and EN 60079-31 (ATEX certified heaters) or to specifications IEC 60079-0, IEC 60079-1, IEC 60079-7 and IEC 60079-31 (IECEx certified heaters) .

The protection mode with respect to the external explosive environment is:

Ex db IIC T6 ÷T1 Gb (-60°C≤Ta≤+70°C)
Ex tb IIIC T400°C-T85°C Db (-60°C≤Ta≤+70°C) IP68

The protection mode with respect to a potentially explosive environment at the process side is:

Ex eb IIC T6 ÷T1 Gb

The heater label defines both the classification of the area at the process side and the classification of the area towards the external environment, using different rules depending on the type of certification (if ATEX or IECEx, see below).

The protection mode against the risks associated to explosive gases is indicated as "Ex d" if it refers to the external environment while it is indicated as "Ex e" if it refers to the process side.

The protection mode against the risks associated to explosive dusts (which is possible only at the external environment side) is indicated as Ex t. If the heater presents a protection against explosive gases at the process side too, then the protection mode is indicated as Ex e t.

ELECTRICAL CHARACTERISTICS

Maximum nominal voltage:	750	V
Maximum current:	56	A
Nominal frequency:	50/60	Hz

ATEX LABELLING (process side classified)

CE 0477 Ex II 2G/2G Ex db eb IIC T6 ÷T1 Gb/Gb¹ Tcavo/cable xxx°C Tamb tt/TT °C COD. XXXXX-HHH anno/year
II -/2D Ex tb IIIC Txxx°C -/Db IP6X 50/60Hz V xxx/y aaa A ppp kW Timp. xxx°C NR. nnnn

ATEX LABELLING (process side NOT classified)

CE 0477 Ex II -/2G Ex db IIC T6 ÷T1 -/Gb Tcavo/cable xxx°C Tamb tt/TT °C COD. XXXXX-HHH anno/year
II -/2D Ex tb IIIC Txxx°C -/Db IP6X 50/60Hz V xxx/y aaa A ppp kW Timp. xxx°C NR. nnnn

IECEx LABELLING (process side classified)

Ex db eb IIC T6 ÷T1 Gb/Gb¹ Tcavo/cable xxx°C Tamb tt/TT °C COD. XXXXX-HHH anno/year
Ex tb IIIC Txxx°C -/Db IP6X 50/60Hz V xxx/y aaa A ppp kW Timp. xxx°C NR. Nnnn

IECEx LABELLING (process side NOT classified)

Ex db IIC T6 ÷T1 -/Gb Tcavo/cable xxx°C Tamb tt/TT °C COD. XXXXX-HHH anno/year
Ex tb IIIC Txxx°C -/Db IP6X 50/60Hz V xxx/y aaa A ppp kW Timp. xxx°C NR. Nnnn

0477	nr. of the Notified Body having in charge the ATEX surveillance
II	group II (surface apparatus)
2	category 2 apparatus
G	explosive atmosphere with presence of gases, vapours, fogs
D	explosive atmosphere with presence of dusts
Ex eb IIC T6 ÷T1 Gb	type of protection against explosive gases, gas group IIC, temperature class
Tcavo/cable xx°C	maximum temperature that the power supply cables shall withstand
Tamb tt/TT	allowable ambient temperature range. If not specified it corresponds to -20/+40 °C
COD. XXXXX-HHH	Product Code, Type of Product (within the range 80÷700)
anno/year	year of manufacturing of the product
Ex tb IIIC Txxx°C Db	type of protection against explosive dusts, type of dusts, maximum allowable surface temperature in presence of explosive atmosphere with presence of dusts
IP6X	IP degree of protection of the electrical contact box
V xxx/y aaa A ppp kW	electrical data (supply voltage, current, power)
Timp.	maximum allowable plant operating temperature
NR. Nnnn	product serial number

¹ The labelling II 3G/2G Ex db ec IIC T6÷T1 Gc/Gb (ATEX) or Ex db ec IIC T6÷T1 Gc/Gb (IECEx) is also possible

MASTERWATT		SPECIFIC TEST REPORT		n° 684/2022	
Riscaldatori elettrici		X0609		Date: 25/05/2022	
Customer: 4701		Order Confirmation: 2022/1531-3/3		Drawing n. 14289	
Order n. 343 d.06/04/2022				Ordered Quantity 8	
Code MASTERWATT		Voltage 380 V/3		Power 24000 W	
78ZTC240D000003				Tested Quantity 8	
Heater Certified in accordance with EN 60079-0/-1/-31					
II -I2G Ex db IIC -IGb - II -I2D Ex tb IIIC -IDb					
Gas Group IIC		Certificate n°:		18 ATEX 2960 X	
Heater Temperat. Class: T4		heater serial n°:		23532 + 23539	
Cable Design Temperature: 90		housing prof. degree:		IP65	
Contact Housing Proof Pressure Test: NOT REQUESTED					

VISUAL AND DIMENSIONAL CONTROLS		
gasket presence and continuity: POSITIVE	Dimensional Control POSITIVE	Safety sensors control POSITIVE
HEATER HYDRAULIC TEST		
Code of the adapter to be used: M270FE72143878		
Test Duration > 2 min.	pressure : 10 bar	Result : SUCCESSFUL

ELECTRICAL VERIFICATIONS		OHMIC Value measured at ambient temperature (Measured between Phase and Phase)		
NOMINAL VALUE				MEASURED
Ω		$\Omega +5\%$	$\Omega -5\%$	
Stage n. 1 -	12.03	12.63	11.43	12,23 ÷ 12,43
DIELECTRIC RIGIDITY		at 1000 V + 2 x Nominal Voltage - duration 60 seconds or (at 1000 V + 2 x Nominal Voltage) x 1,2 - duration > 0,1 seconds		
Required Test Voltage	Max dispersion current	Measured Test Voltage	Measured dispersion current	
2160 V	2.87 mA	2160 V	1,66 mA	
INSULATION RESISTANCE		500 V.c.c. MEGGER		
Nominal Value	200 M Ω	Measured Value	> 200 M Ω	

Notes:	The Test Responsible
	MASTERWATT

Code X00609
Drawing n° 14289

Customer: PEGORARO
Prod. Code 78ZTC240A000003

Ref. 39010022
Date: 27/02/2019

The sketch is just illustrative

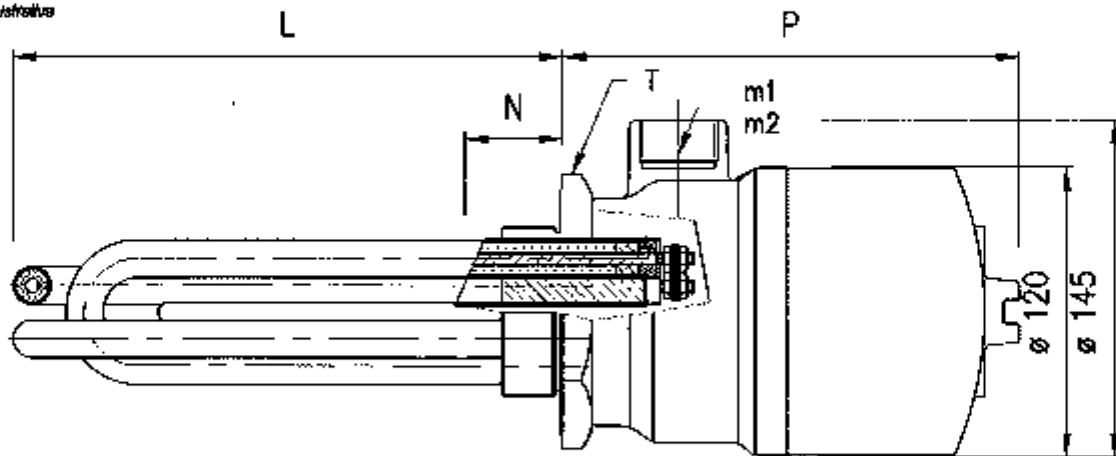

Release: 00

L	N	R	T	P	m1	m2	Operating T°
1150	80	0	2_1/2" Gas	180	1"NPT	1/2"NPT	max 95 °C

Plug-Mounted Heater 2_1/2" Gas made of Stainless Steel AISI 316
Power 24,00 kW - Voltage 380 V / 3Ph. - Current = 36,5 A

Composed by:

- n° 3 armoured electric resistances made of Stainless Steel AISI 316Ti Sheath - 16 mm diameter
- Overall Length: 2343 mm - Bending Type: U bend - Length Below Ledge: 1150 mm
- Unit power 8000 W - Voltage 380 V - Power density 7,5 W/cm²
- Electro-welded on Screw-Plug 2_1/2" Gas made of Stainless Steel AISI 316 - plug type: integral

Hot Head Heater Certified by EPT based on EN 60079-0/1/31 II 2GD Exd IIC t4 - Ex tb IIIC T 135 °C
Contact Housing Protection IP65
Certificate validity for Class I - Zone 1 / 2 - Ambient T° -20 + 40°C - Maximum operating T° 100°C

Safety Devices:

- n° 1 - Thermostat with Manual reset - operating range 0/150 °C for fluid OVERTEMPERATURE control
thermostat set point = 95 °C
- n° 1 - Thermostat with automatic reset - operating range 30/90 °C for fluid temperature control
thermostat set point = 70 °C

Coherence with Certificate EPT 18 ATEX 2960 X positively verified

MASTERWATT

Planezza 12/04/2022

Spelle
PEGORARO GAS TECHNOLOGIES SRL
VIA DELLA TECNICA 28
36100 VICENZA (VI)



DICHIARAZIONE DI CONFORMITA' UE / UE DECLARATION OF CONFORMITY
DECLARATION DE CONFORMITE UE / KONFORMITÄTSERKLÄRUNG UE

Apparecchiatura Elettrica / Electrical Equipment / Equipment Electrique / Elektrische Ausrüstung

Gruppo / Group / Groupe / Gruppe II 2G / II 2D

Riscaldatore corazzato / Armoured Heater / Rechauffeur Cuirassé / Gepanzerte Heizung

TIPO / TYPE / TYPE / ART **GTF 90/162**

78ZTC240A000003 - Riscaldatore su Tappo 2" 1/2 Ex db IIC T4 Gb 380V/3 24 kW
78ZTC240A000003 - Plug-Mounted Heater 2" 1/2 Ex db IIC T4 Gb 380V/3 24 kW
78ZTC240A000003 - Réchauffeur sur Bouchon 2" 1/2 Ex db IIC T4 Gb 380V/3 24 kW
78ZTC240A000003 - Heizung auf Stöpsel 2" 1/2 Ex db IIC T4 Gb 380V/3 24 kW

Conferma d'Ordine/Confirmation de Commande/Order Confirmation/Auftragsbestätigung :

1531-3/3_2022 - S/N: 23532 + 23539

Dichiaro sotto la nostra esclusiva responsabilità che il prodotto al quale questa dichiarazione si riferisce è conforme prescrizioni della Direttiva CEE 2014/34/UE e delle Norme Europee EN 60079-0:2018, EN 60079-1:2014 ed EN 60079-31:2014

- L'organismo notificato 0477 (***) ha effettuato un esame UE di Tipo ed ha rilasciato il Certificato EPT 18 ATEX 2960 X
- Garanzia della qualità dei prodotti rilasciata dall'Organismo Notificato 0477 (***)

We declare, under our sole responsibility, that the product referred to in this declaration complies with the prescriptions of EEC Directive 2014/34/UE, and of European Specifications EN 60079-0:2018; EN 60079-1:2014 and EN 60079-31:2014

- The Notified Body 0477 (***) has performed an EU-Type examination and has issued the Certificate "EPT 18 ATEX 2960 X"
- Product Quality Assurance verified by Notified Body 0477 (***)

Nous Déclarons sous notre responsabilité exclusive que le produit auquel cette déclaration se réfère est conforme aux prescriptions de la Directive CEE 2014/34/UE, et des Normes Européennes EN 60079-0:2018, EN 60079-1:2014 et EN 60079-31:2014

- L'Organisme Notifié 0477(***) a effectué une examen UE du Type et il * émis le Certificat EPT 18 ATEX 2960 X
- Garantie de Qualité des produits contrôlé par Organisme Notifié 0477 (***)

Wir erklären unter unserer ausschließlichen Verantwortung, dass das in der vorliegenden Erklärung beschriebene Produkt an EWG Norme 2014/34/UE, europäischen Norme EN 60079-0:2018, EN 60079-1:2014 und EN 60079-31:2014 entspricht

- Der Zustellerbüros 0477 (***) hat eine EU-Artprüfung durchgeführt und hat die Bescheinigung EPT 18 ATEX 2960 X ausgestellt
- Qualitätsgarantie den Produkten von Zusteller Büros 0477 geprüft (***)

Masterwatt S.r.l.
R. Ravaglia
Presidente/President

(**) EPT - Eurofins Product Testing Italy S.r.l. - Via Cuorgnè, 21 - 10156 Torino - Italia

Internet: www.masterwatt.it
e-mail: info@masterwatt.it

MASTERWATT S.r.l. Via Collegno, 31 - 10044 Planezza (TO)
Tel. +39-011-9661626 - Fax. +39-011-9671422 - Fax Acquisti +39-011-9675549
C.C.I.A.A. Torino N. 607748 Tribunale Torino Reg. Soc. N. 609/62
Codice Fiscale / Partita IVA IT 02777110012 - N : Meccanografico Export TO 000843

CLIENTE CUSTOMER	
---------------------	--

PROGETTO PROJECT	ELECTIRC SWITCHBOARD 24 kW 400 V
---------------------	-------------------------------------

--	--

COPIA CONTROLLATA	<input type="checkbox"/>
COPIA NON CONTROLLATA	<input type="checkbox"/>



REV.<02>	DESCRIZIONE	DISEGNATORE	CONTROLLATO	APPROVATO	DATA
REV.<01>	DESCRIZIONE	DISEGNATORE	CONTROLLATO	APPROVATO	DATA
REVISIONE REVISION	DESCRIZIONE DESCRIPTION	DIS. SIGNATURE	CONTR. CHECKED	APPROVED	DATA DATE

--

DATI DI PROGETTI DATA PROJECT	POTENZA INSTALLATA	24 kW
	TENSIONE NOMINALE	400 V±
	SISTEMA ELETTRICO	3F + PE
	CORRENTE NOMINALE CON COS. φ 0.9	63 A
	CONTEMPORANEITA'	100 %
	CORRENTE DI CORTO CIRCUITO Icu	10 kA
	Schema Standard	SCHEMA_STANDARD

NOTE	
------	--

ATTENTION: COMPULSORY INSTALLATION AT CUSTOMER CARE.

ATTENZIONE: MONTAGGIO OBBLIGATORIO A CURA DEL CLIENTE

CIRCUIT BREAKER

INTERRUTTORE DIFFERENZIALE AUTOMATICO

MAX CAPACITY 80 A

CORRENTE MAX. 80 A

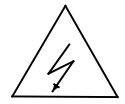

ATTENTION: MAKE SURE OF THE PERFECT GROUNDING OF THE ELECTRICAL CONTROL PANEL BEFORE GIVING TENSION TO IT

ATTENZIONE: PRIMA DI DARE TENSIONE AL QUADRO ELETTRICO ASSICURARSI DELLA SUA PERFETTA MESSA A TERRA

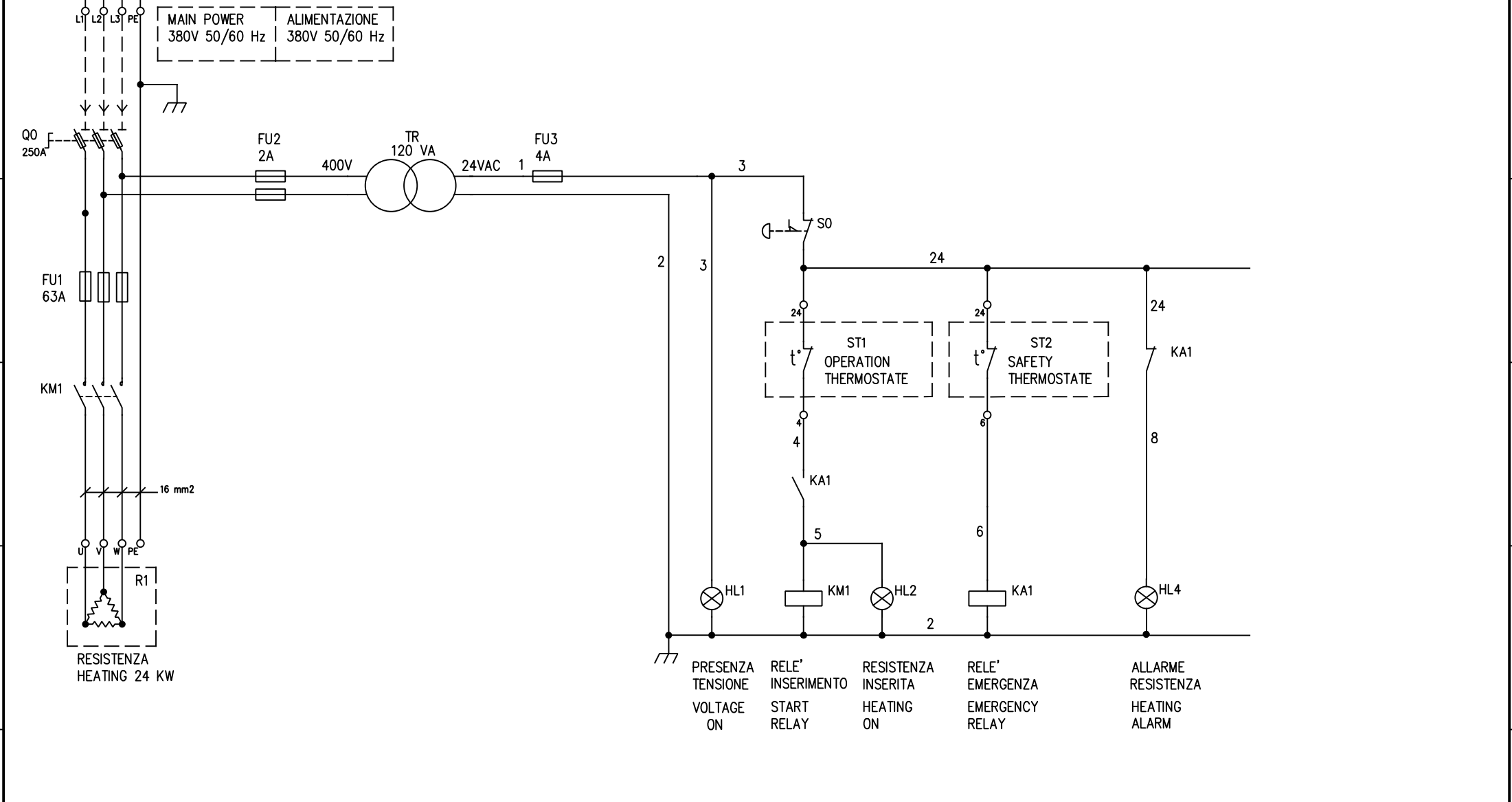

		DATA	30/11/2015	 <small>VICENZA (ITALY)</small>		PEGORARO					
		DISEG.	A.C.			EC024_380_007_0		EC024_380_007_0.DWG		FOGLIO 2 DI 3	
		VISTO	L.P.			SEGUE					
REV.	MODIFICA	DATA	FIRMA	APPR.	M.C.	SOST. IL:	SOST. DA:	ORIGINE:			

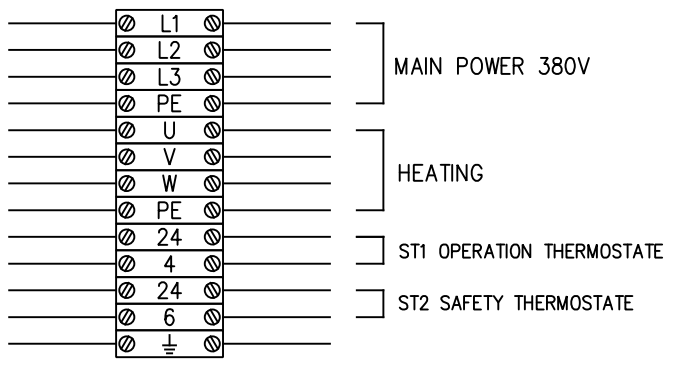

				DATA	30/11/2015				PEGORARO		
				DISEG.	A.C.						
				VISTO	L.P.						
REV.	MODIFICA	DATA	FIRMA	APPR.	M.C.	SOST. IL:	SOST. DA:	ORIGINE:	EC024_380_007_0	EC024_380_007_0.DWG	FOGLIO 3 DI 3
1	2	3	4	5	6	7	8				SEGUE



DICHIARAZIONE DI CONFORMITA'
DECLARATION OF CONFORMITY

PRD0000373
REV.00
del 06/03/2017

IT

Noi, FORALBA Srl con sede in Via dell'Economia n. 131 36100 VICENZA (Italia), dichiariamo sotto la nostra esclusiva responsabilità che il quadro elettrico modello

QUADRO EL. COD: 37010035 IP65 per Ecovap 24KW 380V
MATRICOLA: 829 ordine N°765

fornito alla società PEGORARO GAS TECHNOLOGIES Srl con sede in Via Meucci n. 77 36057 ARCUGNANO (Italia) è conforme a:

1. Apparecchiature assiemate di protezione e di manovra per bassa tensione (quadri BT) secondo la norma EN 60204-1
2. I componenti utilizzati sono conformi alla Direttiva CE

La presente dichiarazione è rilasciata secondo le prescrizioni della Direttiva Bassa Tensione della Comunità Europea del 19 Febbraio 1973 recepita in Italia con legge n. 791 del 18.10.1977.

NB: IL FATTO CHE LE PROVE SIANO STATE EFFETTUATE PRESSO L'OFFICINA DEL COSTRUTTORE, NON ESONERA L'INSTALLATORE DELL'APPARECCHIATURA DALL'OBBLIGO DI VERIFICARE LA STESSA DOPO IL TRASPORTO E L'INSTALLAZIONE

EN

We, FORALBA Srl with headquarter in Via dell'Economia n. 131 36100 VICENZA (Italy), declare under our responsibility that the control box

*CONTROL PANEL COD. 37010035 IP65 for Ecovap 24KW 380V
SERIAL NUMBER: 829 order N°765*

supplied to PEGORARO GAS TECHNOLOGIES Srl with headquarter in Via Meucci n.77 36057 ARCUGNANO (Italy)

is conformed to:

1. *EN 60204-1 Low voltage of switchgear and protection control box*
2. *The components used are in accordance to CE*

This declaration of conformity is issued in accordance to EC Low Tension Directive dated 19 February 1973 – Italian Law no. 791 dated 18 October 1977.

PS: THE INSTALLER MUST CHECK THE EQUIPMENT AFTER RECEIVING THE GOODS AND BEFORE COMMISSIONING

Vicenza.....01/08/2022

foralba srl